



Owner's Manual

Geneva | Niagara | Tahitian

Hawaiian | Martinique | Kauai

TABLE OF CONTENTS

WELCOME	1
IMPORTANT SAFETY INSTRUCTIONS	2
CONTROLS AND EQUIPMENT	5
INSTALLATION	11
ELECTRICAL INSTALLATION	12
START-UP AND REFILL PROCEDURES	13
SPA COVER INSTALLATION	14
CUSTOMIZING YOUR MASSAGE	15
JET MENUS	18
OPERATING INSTRUCTIONS	22
EQUIPMENT COMPARTMENTS	24
MAINTENANCE	26
• Filter Cartridge Removal and Cleaning Instructions.....	26
• Spa Light.....	26
• Diverter Valve Maintenance.....	26
• Winterizing Your Spa.....	27
• Draining Your Spa.....	28
• Care of the Spa Pillows.....	29
• Care of the Exterior.....	29
• Care of the Spa Cover.....	29
WATER QUALITY AND MAINTENANCE	30
• Methods for Testing the Spa Water.....	30
• The Caldera™ Spa Water Maintenance Program.....	31
• Chlorine (Sodium Dichlor).....	32
• Ozone (Optional).....	34
• Common Water Chemistry Questions.....	35
• Water Terminology.....	35
• Caldera™ Ozone System (Optional).....	36
SERVICE	38
• Acts Invalidating Warranty.....	38
• Disclaimers.....	38
• Watkins Customer Service.....	38
SPA TROUBLESHOOTING	39
LCD MESSAGES	40

WELCOME

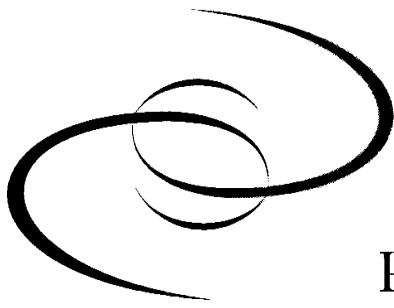

CalderaSpas™

Pure Comfort

***Congratulations on your decision to enjoy the finest spa available...
Welcome to the growing family of Caldera™ Spa owners.***

***Watkins
Manufacturing
Corporation***

Owner's Manual

This Owner's Manual will acquaint you with your new spa's operation and general maintenance. We suggest that you take some time to carefully review all sections. Please keep this manual available for reference.

If you have any questions about any aspect of your spa's set-up, operation or maintenance, contact your authorized Caldera™ Spa dealership. They are trained professionals who are familiar with the product as well as new spa ownership concerns. Their expertise will facilitate the enjoyment of your new Caldera™ Spa.

The Serial Number/Identification label is located within the equipment compartment of your Caldera™ Spa. The serial number should also be documented on the delivery receipt from your dealer.

IMPORTANT: Watkins Manufacturing Corporation reserves the right to change specifications or design without notification and without incurring any obligation.

DATE PURCHASED: _____

DATE INSTALLED: _____

DEALER: _____

ADDRESS: _____

TELEPHONE: _____

SPA MODEL/SERIAL NUMBER: _____

COVER SERIAL NUMBER: _____

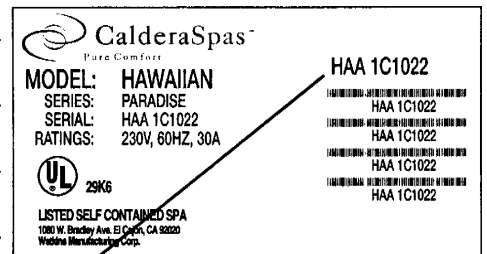

NOTE: This is an example. Your spa's label will contain different information. Peel off top sticker and place here.

In most cities and counties, permits will be required for the installation of electrical circuits or the construction of exterior surfaces (decks and gazebos). In addition, some communities have adopted residential barrier codes which may require fencing and/or self-closing gates on the property to prevent unsupervised access to a pool (or spa) by children under 5 years of age. Your Caldera™ Spa is equipped with a locking cover that meets the ASTM F1346-91 Standard for Safety Covers and as a result, is usually exempt from most barrier requirements. As a general practice, your local Building Department will inform you of any applicable barrier requirements at the time a permit is obtained for the installation of an electrical circuit. Your Caldera™ Spa Dealer can provide information on which permits may be required.

IMPORTANT SAFETY INSTRUCTIONS

I. SAFETY INFORMATION

IMPORTANT SAFETY INSTRUCTIONS READ AND FOLLOW ALL INSTRUCTIONS

AVOIDING THE RISK TO CHILDREN

DANGER:

- **RISK OF CHILD DROWNING.** Extreme caution must be exercised to prevent unauthorized access by children. To avoid accidents, ensure that children cannot use a spa unless they are supervised at all times.

WARNING:

- To reduce the risk of injury, do not permit children to use this product unless they are closely supervised at all times.
- To reduce the risk of injury, lower water temperatures are recommended for young children. Children are especially sensitive to hot water.

DO:

- Make sure you always lock the child resistant locks after using the spa for your children's safety. Every Caldera™ Spa is equipped with a locking cover that meets the ASTM F1346-91 Standard for Safety Covers.
- Test the water temperature with your hand before allowing your child to enter the spa to be sure that it's comfortable. Children are especially sensitive to hot water.
- Remind children that wet surfaces can be very slippery. Make sure that the children are careful when entering or exiting the spa.

DON'T:

- Allow children to climb onto the spa cover.
- Allow children to have unsupervised access to the spa.

AVOIDING THE RISK OF ELECTROCUTION

Risk of electrocution

- Connect only to a grounded source.
- Do not bury the power cord. A buried power cord may result in death or serious personal injury due to electrocution if direct burial-type cable is not used, or if improper digging occurs.
- A ground terminal (pressure wire connector) is provided on the control box inside the unit to permit connection of a minimum No. 8 AWG solid copper bonding conductor between this point and any metal equipment, metal water pipe, metal enclosures of electrical equipment, or conduit within five feet (1.5 m) of the unit as needed to comply with local requirements.

WARNING:

- To reduce the risk of electrical shock, replace a damaged cord immediately. Failure to do so may result in death or serious personal injury due to electrocution.
- Your spa is provided with a Ground Fault Circuit Interrupter for user and equipment protection. To ensure proper operation of this important safety device, test according to the following instructions per electrical configuration.

230 volt, permanently installed or converted models:

- A ground terminal is provided on the terminal block located inside the control box. To reduce the risk of electric shock, connect this terminal to the grounding terminal of your electrical service or supply panel with a continuous green, insulated copper wire. The wire must be equivalent in size to the circuit conductors supplying the equipment. In addition, a bonding terminal (pressure wire connector) is provided on the outside of the control box for bonding to local ground points. To reduce the risk of electric shock, this connector should be bonded with a No. 8 AWG solid copper wire to any metal ladders, water pipes, or other metal within 5 feet (1.5 m) of the spa to comply with local requirements. The means of disconnection must be readily accessible, but must be installed at least 5 feet (1.5 m) from the spa.
- Your spa is provided with a suitably rated circuit breaker to open all ungrounded supply conductors.
- Your spa uses ground fault circuit interrupters in the electrical subpanel. Before each use of the spa and with the unit operating, push the Test button on each breaker. The switch should click over to the "Trip" position. Wait 30 seconds and reset each GFCI breaker by switching it completely off and then completely on. The switch should then stay on. If either of the interrupters does not perform in this manner, it is an indication of an electrical malfunction and the possibility of an electric shock. Disconnect the power until the fault has been identified and corrected.

IMPORTANT SAFETY INSTRUCTIONS

DANGER: RISK OF ELECTRICAL SHOCK

- Install at least 5 feet (1.5 m) from all metal surfaces. A spa may be installed within 5 feet of a metal surface if each metal surface is permanently connected by a minimum No. 8 AWG solid copper conductor attached to the wire ground connector on the terminal box that is provided for this purpose if in accordance with National Electrical Code ANSI/NMFA70-1993.
- Do not permit any electrical appliances, such as a light, telephone, radio, or television within 5 feet (1.5 m) of a spa. Failure to maintain a safe distance may result in death or serious personal injury due to electrocution if the appliance should fall into the spa.
- Install your spa in such a way that drainage is away from the electrical compartment and from all electrical components.

DO:

- Be sure your spa is connected to the power supply correctly - use a licensed electrical contractor.
- Disconnect the spa from the power supply before draining the spa or servicing the electrical components.
- Test the Ground Fault Circuit Interrupter(s) before each use.

DON'T:

- Use the spa with the equipment compartment door removed.
- Place electrical appliances within 5 feet (1.5m) of the spa.
- Use an extension cord to connect the spa to its power source. The cord may not be properly grounded and the connection is a shock hazard. An extension cord may cause a voltage drop, which will cause overheating of the jet pump motor and motor damage.
- Attempt to open the electrical control box. There are no user serviceable parts inside.

RISKS TO AVOID

DANGER: RISK OF INJURY

- To reduce the risk of injury to persons, DO NOT remove floating weir, basket and filter located in the filter compartment while the spa is running.
- The suction fittings in the spa are sized to match the specific water flow created by the pump. Should the need arise to replace the suction fittings or the pump, be sure that the flow rates are compatible.
- There is a danger of slipping and falling. Remember that wet surfaces can be very slippery. Take care when entering or exiting the spa.

Increased side effects of medication

- The use of drugs, alcohol or medication before or during spa use may lead to unconsciousness with the possibility of drowning.
- Persons using medications should consult a physician before using a spa; some medication may cause a user to become drowsy, while other medication may affect heart rate, blood pressure and circulation.
- Persons taking medications which induce drowsiness, such as tranquilizers, antihistamines or anticoagulents should not use the spa.

Health problems affected by spa use

- Pregnant women should consult a physician before using spa.
- Persons suffering from obesity or with a medical history of heart disease, low or high blood pressure, circulatory system problems or diabetes should consult a physician before using spa.

Unclean water

- Keep the water clean and sanitized with correct chemical care. The recommended levels for your Caldera™ Spa are:

Free Available Chlorine (FAC):	3.0-5.0 ppm
Water pH:	7.4-7.6
Total Alkalinity:	125-150 ppm
Calcium Hardness:	150-200 ppm

(Refer to Water Quality and Maintenance section for complete instructions.)

IMPORTANT: Turn on the jet pump for a least ten minutes after adding ANY spa water chemicals into the filter compartment.

- Clean the filter cartridges at least monthly to remove debris and mineral buildup which may affect the performance of the hydromassage jets, limit the flow, or trip the high limit thermostat which will turn off the entire spa.

AVOIDING THE RISK OF HYPERTHERMIA

Prolonged immersion in hot water can result in HYPERTHERMIA, a dangerous condition which occurs when the internal temperature of the body reaches a level above normal (98.6°F). The symptoms of hyperthermia include unawareness of impending hazard, failure to perceive heat, failure to recognize the need to exit the spa, physical inability to exit the spa, fetal damage in pregnant women, and unconsciousness resulting in a danger of drowning.

WARNING:

The use of alcohol, drugs, or medication can greatly increase the risk of fatal hyperthermia in hot tubs and spas.

IMPORTANT SAFETY INSTRUCTIONS

TO REDUCE THE RISK OF INJURY:

- The water in the spa should never exceed 104°F. Water temperatures between 100°F and 104°F are considered safe for a healthy adult. Lower water temperatures are recommended for extended use (exceeding 10 minutes) and for young children. Extended use can cause hyperthermia.
- Pregnant or possibly pregnant women should limit spa water temperatures to 100°F. Failure to do so may result in permanent injury to your baby.

AVOIDING THE RISK OF SKIN BURNS:

- To reduce the risk of injury, before entering a spa the user should measure the water temperature with an accurate thermometer, since the tolerance of temperature-regulating devices may vary by as much as $\pm 5^\circ\text{F}$.
- Test the water with your hand before entering the spa to be sure it's comfortable.

SAFETY SIGN

Each Caldera™ Spa is shipped with a SAFETY SIGN in the owner's package. The sign, which is required as a condition of Product Listing, should be permanently installed where it is visible to the users of the spa. To obtain additional SAFETY SIGNS, contact your Caldera™ Spa Dealer and request Part #003021

IMPORTANT SPA INSTRUCTIONS

The following contains important spa information, and we strongly encourage you to read and apply them.

DO:

- Use and lock the cover when the spa is not in use, whether it is empty or full.
- Follow the Spa Care and Maintenance recommendations stated in this manual.
- Use only approved accessories and recommended spa chemicals and cleaners.

DON'T:

- Leave the Caldera™ Spa exposed to the sun without water or the cover in place. Exposure to direct sunlight can cause solar distress of the shell material.
- Roll or slide the spa on its side. This will damage the siding.
- Lift or drag the cover by using the cover lock straps; always lift or carry the cover by using the handles.
- Attempt to open the electrical control box. There are no user serviceable parts inside. Opening of the control box by the spa owner will void the warranty. If you have an operational problem, carefully go through the steps outlined in the Troubleshooting section. If you are not able to resolve the problem, contact your authorized Caldera™ Spa Dealer. Many problems can easily be diagnosed over the telephone by an Authorized Service Technician.

SAVE THESE INSTRUCTIONS

GENEVA PARADISE

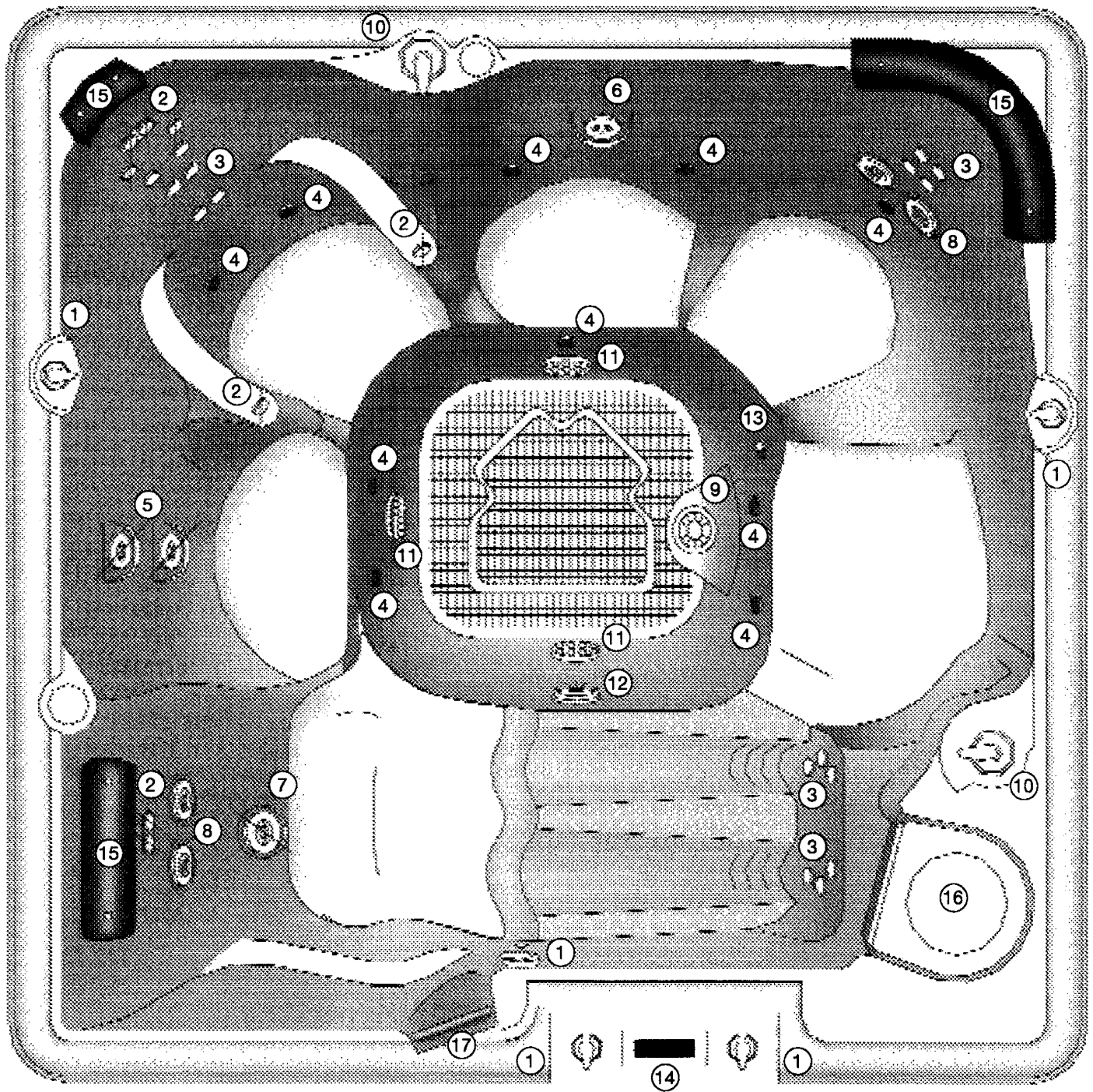

OVERHEAD VIEW

- | | | | | |
|-------------------|-------------------|--------------------|------------------------|---------------|
| 1. Air Control | 5. MagnaSsage Jet | 9. Euphoria Jet | 13. Ozone Jet | 17. Grab Rail |
| 2. Euro-Pulse Jet | 6. Magna Jet | 10. Diverter Valve | 14. Control Panel | |
| 3. Euro Jet | 7. VersaSsage Jet | 11. Drain | 15. Pillow | |
| 4. Air Jet | 8. Versa Jet | 12. Light | 16. Filter Compartment | |

NIAGARA PARADISE

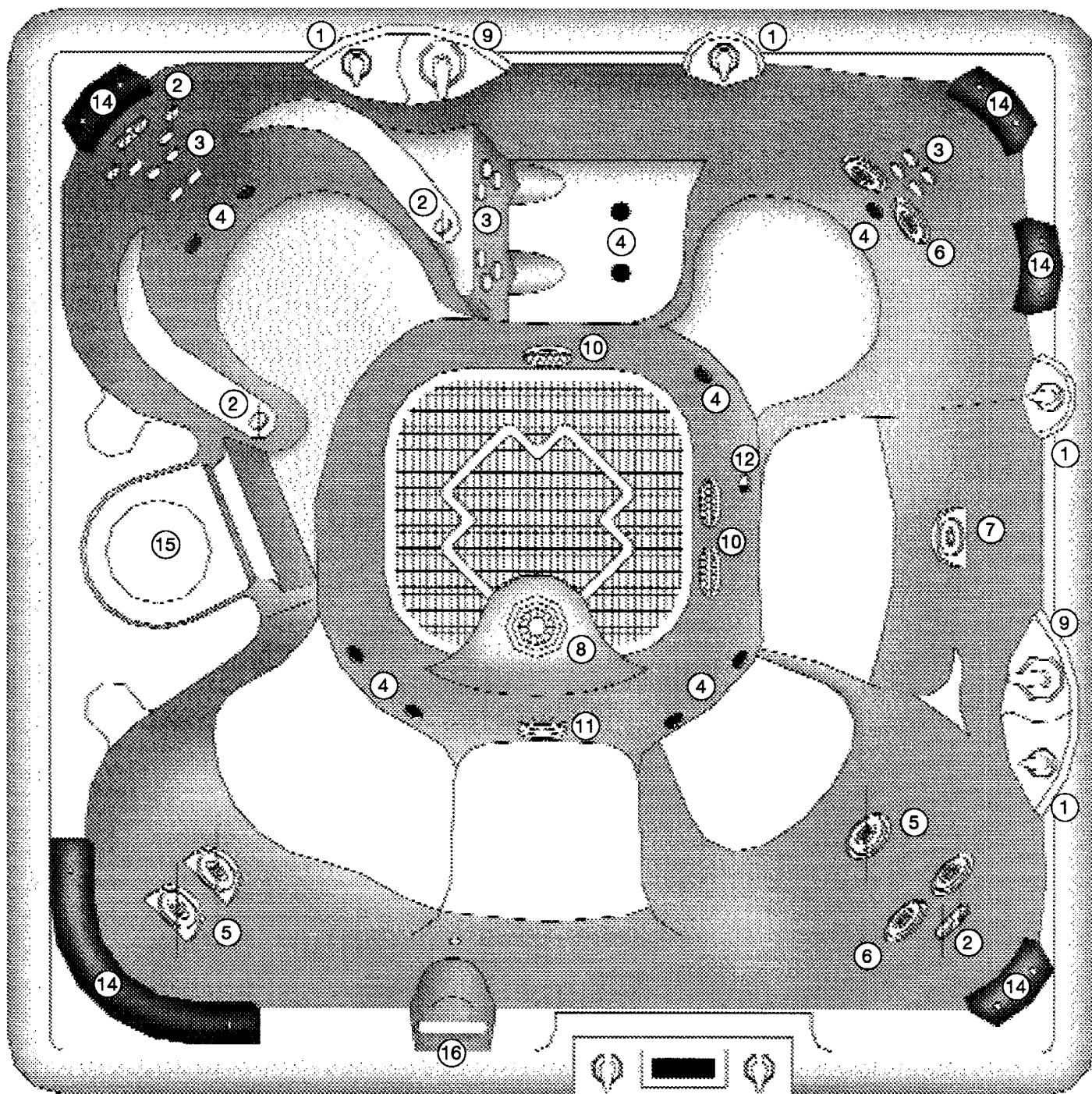

OVERHEAD VIEW

- | | | | |
|-------------------|-------------------|-------------------|------------------------|
| 1. Air Control | 5. VersaSsage Jet | 9. Diverter Valve | 13. Control Panel |
| 2. Euro-Pulse Jet | 6. Versa Jet | 10. Drain | 14. Pillow |
| 3. Euro Jet | 7. Magna Jet | 11. Light | 15. Filter Compartment |
| 4. Air Jet | 8. Euphoria Jet | 12. Ozone Jet | 16. Grab Rail |

HAWAIIAN PARADISE

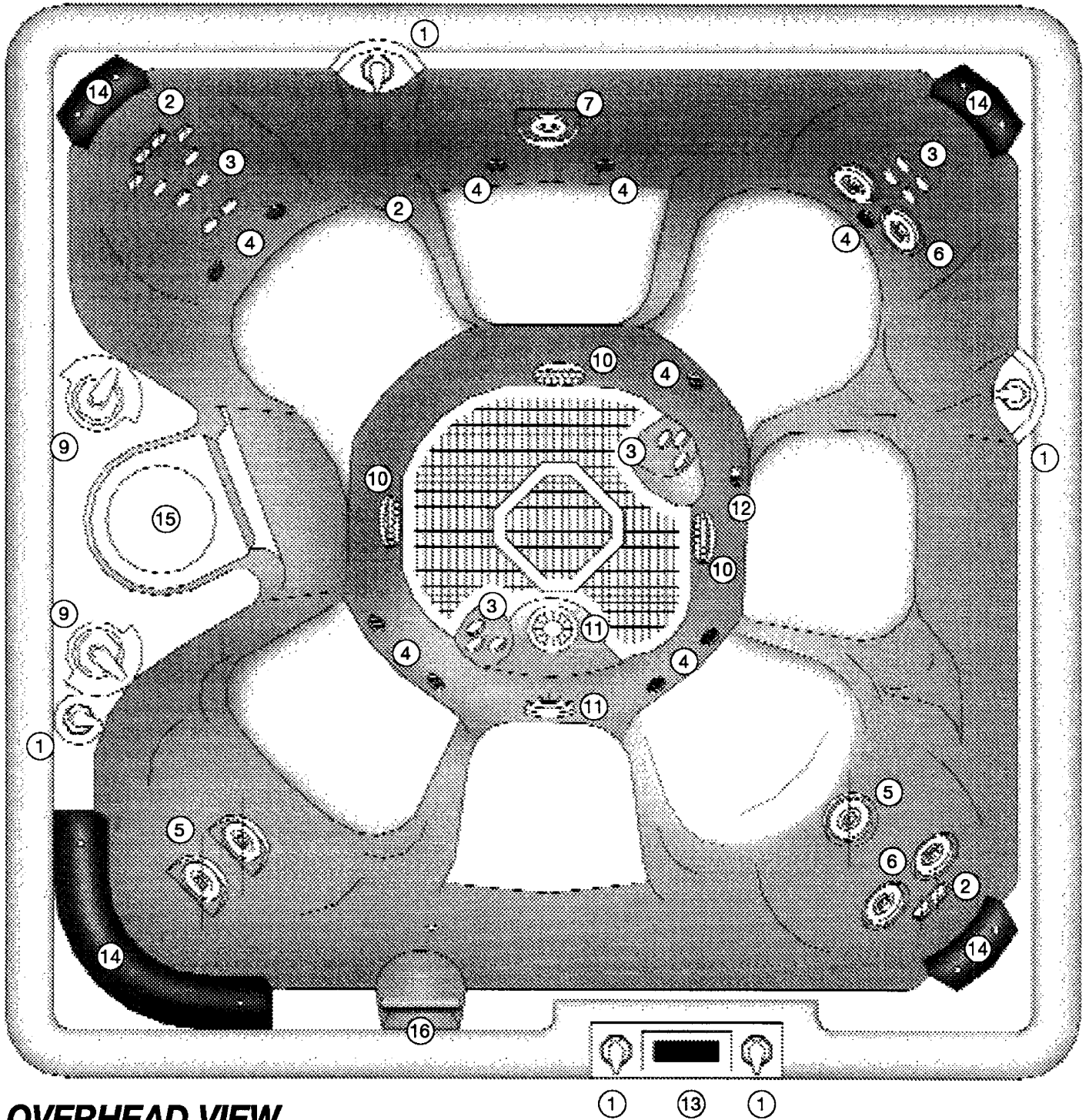

OVERHEAD VIEW

- | | | | |
|-------------------|-------------------|-------------------|------------------------|
| 1. Air Control | 5. VersaSsage Jet | 9. Diverter Valve | 13. Control Panel |
| 2. Euro-Pulse Jet | 6. Versa Jet | 10. Drain | 14. Pillow |
| 3. Euro Jet | 7. Magna Jet | 11. Light | 15. Filter Compartment |
| 4. Air Jet | 8. Euphoria Jet | 12. Ozone Jet | 16. Grab Rail |

TAHITIAN PARADISE

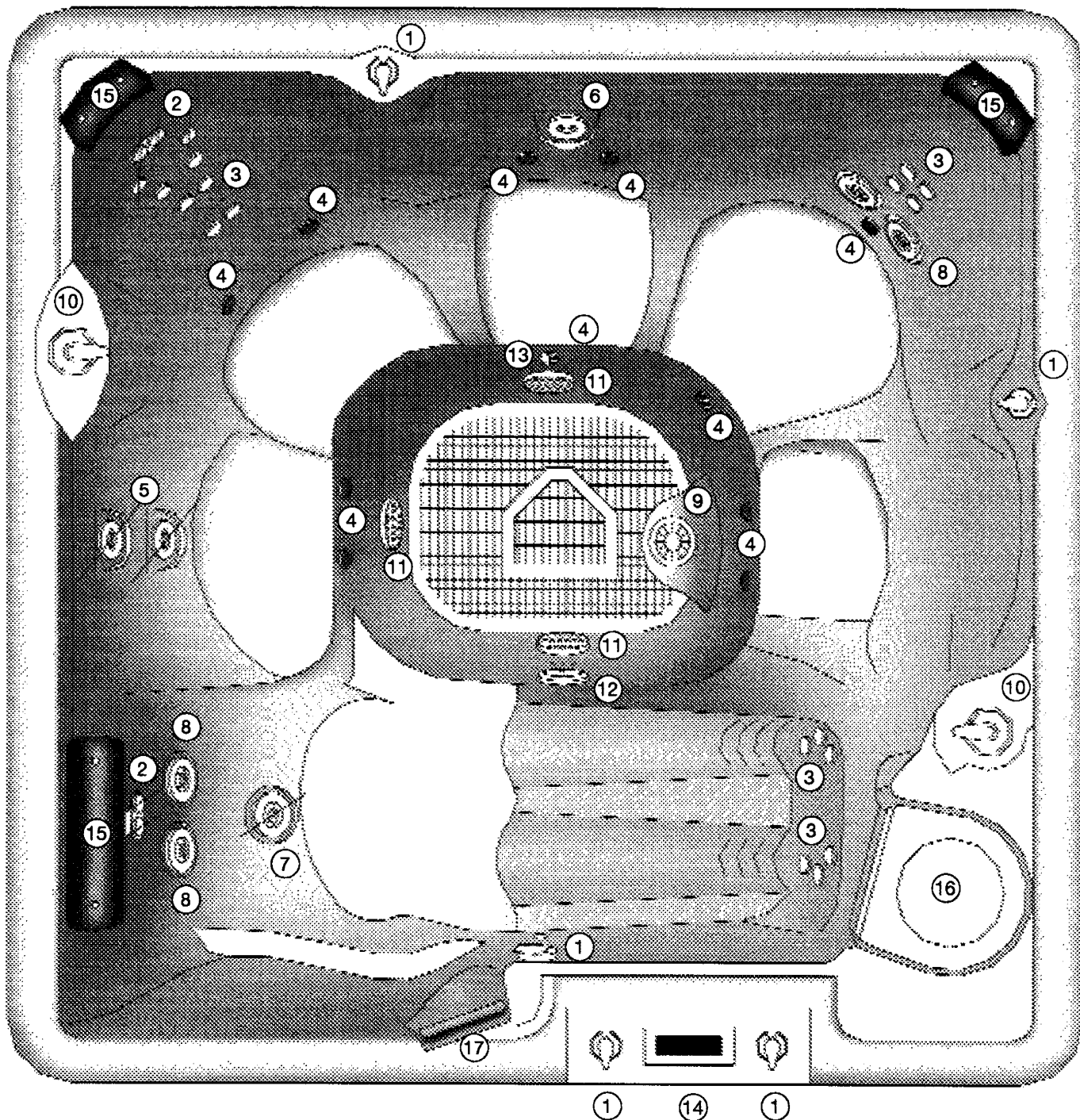

OVERHEAD VIEW

- | | | | | |
|-------------------|-------------------|--------------------|------------------------|---------------|
| 1. Air Control | 5. MagnaSSage Jet | 9. Euphoria Jet | 13. Ozone Jet | 17. Grab Rail |
| 2. Euro-Pulse Jet | 6. Magna Jet | 10. Diverter Valve | 14. Control Panel | |
| 3. Euro Jet | 7. VersaSSage Jet | 11. Drain | 15. Pillow | |
| 4. Air Jet | 8. Versa Jet | 12. Light | 16. Filter Compartment | |

CONTROLS AND EQUIPMENT

MARTINIQUE PARADISE

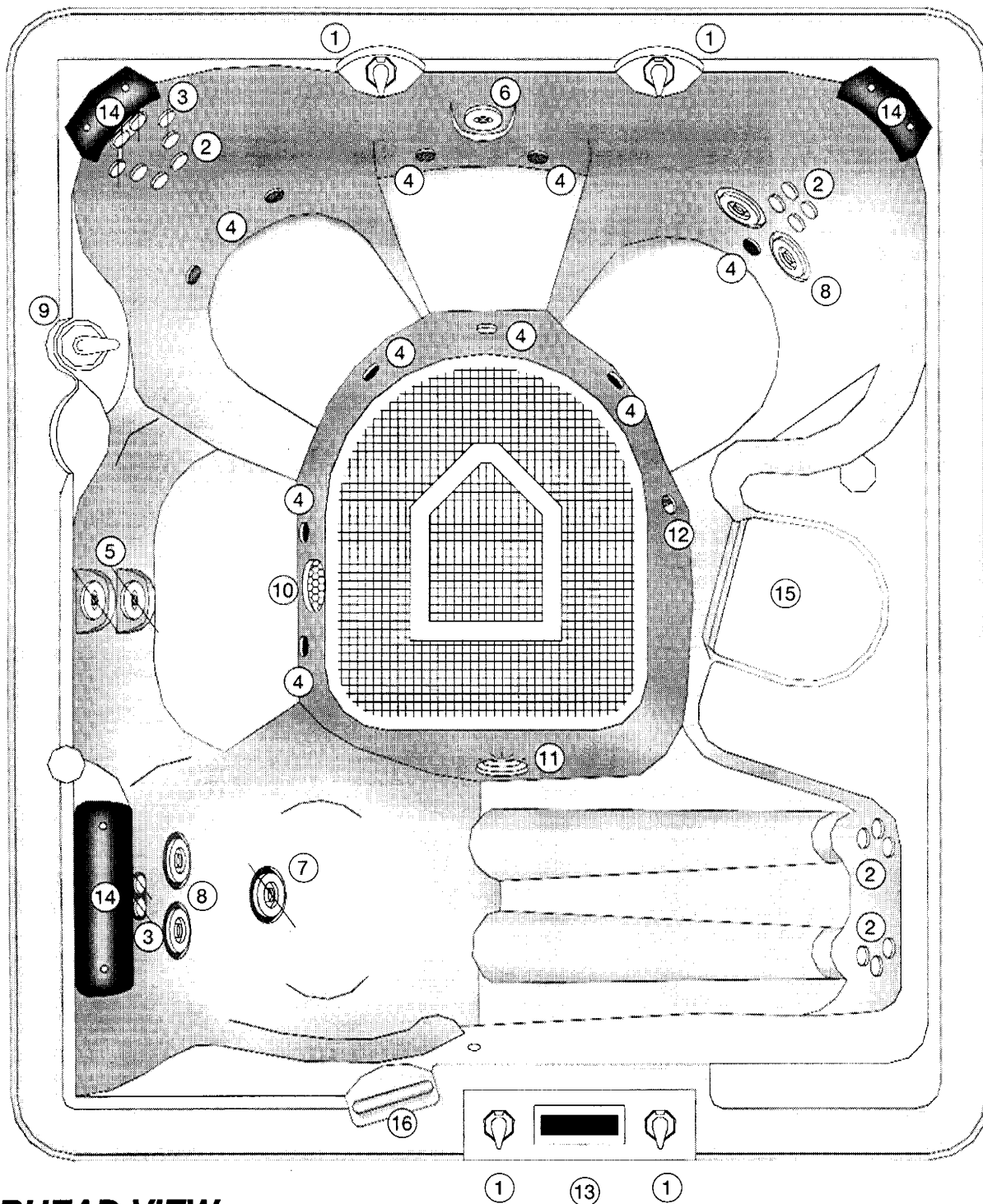

OVERHEAD VIEW

- | | | | |
|-------------------|-------------------|-------------------|------------------------|
| 1. Air Control | 5. MagnaSsage Jet | 9. Diverter Valve | 13. Control Panel |
| 2. Euro Jet | 6. Magna Jet | 10. Drain | 14. Pillow |
| 3. Euro-Pulse Jet | 7. VersaSsage Jet | 11. Light | 15. Filter Compartment |
| 4. Air Jet | 8. Versa Jet | 12. Ozone Jet | 16. Grab Rail |

KAUAI PARADISE

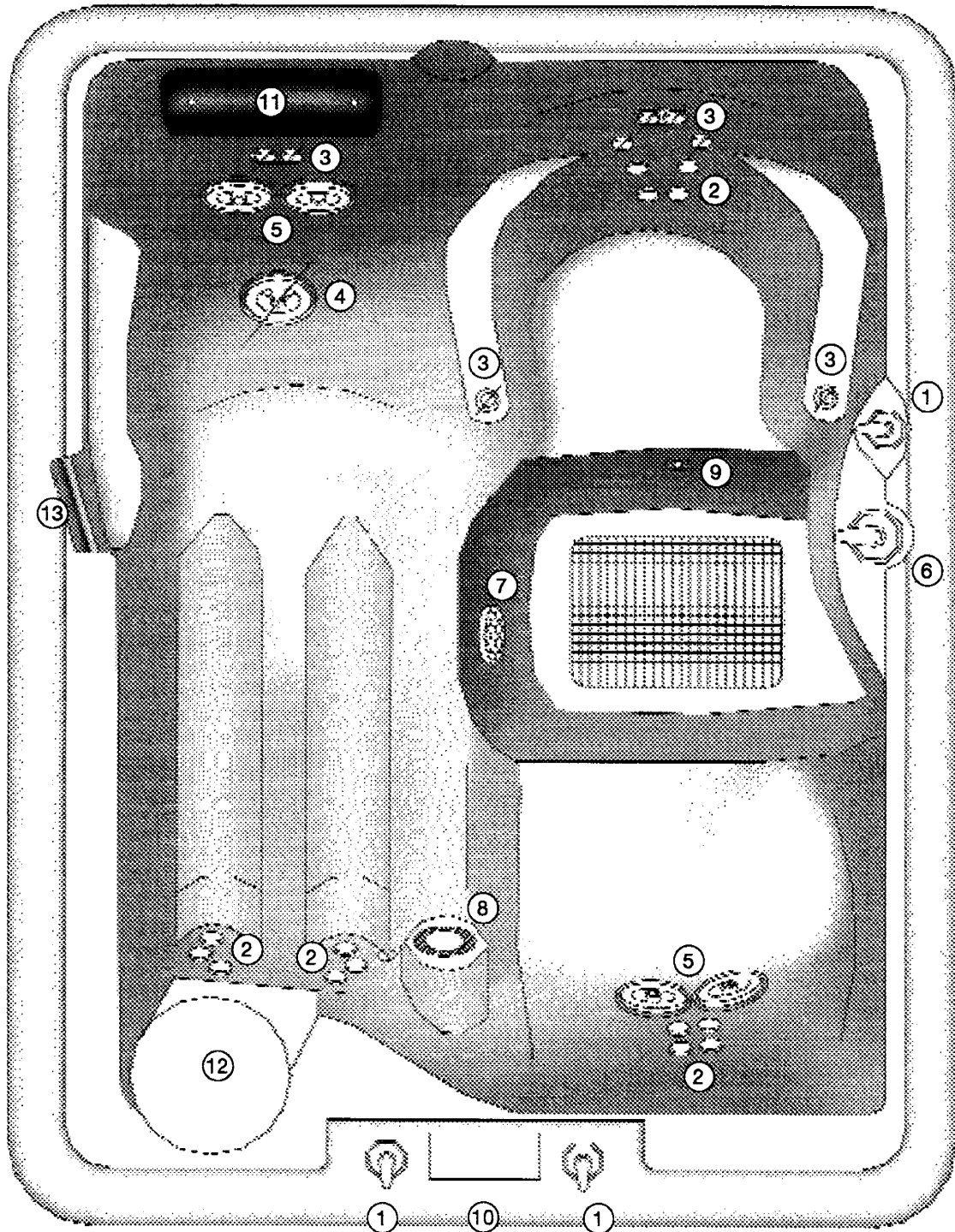

OVERHEAD VIEW

- | | | | |
|-------------------|-------------------|------------------------|---------------|
| 1. Air Control | 5. Versa Jet | 9. Ozone Jet | 13. Grab Rail |
| 2. Euro Jet | 6. Diverter Valve | 10. Control Panel | |
| 3. Euro-Pulse Jet | 7. Drain | 11. Pillow | |
| 4. VersaSage Jet | 8. Light | 12. Filter Compartment | |

INSTALLATION

SITE PREPARATION

You probably have a spot picked out for your new spa, whether it's indoors or outdoors, on a patio or on a deck. Just make sure you check the following:

- Always put your spa on a structurally sound, level surface. A filled spa can weigh a great deal. Make certain that the location you choose can support the weight of your filled spa.
- Don't forget to level your spa before filling it. (See the Spa Leveling section of this manual.)
- Locate your equipment compartment, which houses all of the electrical components, in a place where water will drain away from it. Allowing water into the equipment compartment can damage the electronics, or may result in tripping your house's circuit breaker.
- Leave yourself easy access to the circuit breakers in the subpanel.
- Never let water get into the subpanel. Your 230 volt spa's subpanel is raintight when installed correctly with the door closed. Periodically check these conditions and correct any flaws if detected.
- Leave access to the equipment compartment for periodic spa care and maintenance.

WARNING: Damage to the spa's equipment compartment components or internal plumbing as a result of rodent infestation is NOT covered under your warranty!

OUTDOOR AND PATIO INSTALLATION

No matter where you install your new spa, it's important that you have a solid foundation to support it. Structural damage to the spa resulting from incorrect installation or placement on an inadequate foundation is not covered under the spa's limited warranty.

If you install the spa outdoors, we recommend a reinforced concrete pad at least four inches thick. The reinforcing rod or mesh in the pad should be attached to a bond wire.

DECK INSTALLATION

To be certain your deck can support your spa, you must know the deck's maximum load capacity. Consult a qualified building contractor or structural engineer. To find the weight of your spa, its contents and occupants, refer to the Spa Specification chart. This weight per square foot must not exceed the structure's rated capacity, or serious structural damage could result.

INDOOR/BASEMENT INSTALLATION

Be aware of some special requirements if you place your spa indoors. Water will accumulate around the spa, so flooring materials must provide a good grip when wet. Proper drainage is essential to prevent a build-up of water around the spa. When building a new room for the spa it is recommended that a floor drain be installed. The humidity will naturally increase with the spa installed. Water may get into woodwork and produce dryrot, mildew, or other problems. Check for airborne moisture's effects on exposed wood, paper, etc. in the room. To minimize these effects, it is best to provide plenty of ventilation to the spa area. An architect can help to determine if more ventilation must be installed.

Caldera Spas are equipped with a jet pump shroud to remove excessive heat from the equipment compartment. Find this vent and be sure the vent is not blocked by anything, including carpeting.

Your Caldera Spa Dealer can help you with local information such as zoning regulations and building codes.

SITE PREPARATION

Concrete sloped at 1 inch per 10 feet is preferred so that rain water and water spillover will run off and not puddle underneath the spa (water under the spa for long periods of time may cause the wood to deteriorate). Other options are brick, stepping stone or blocks.

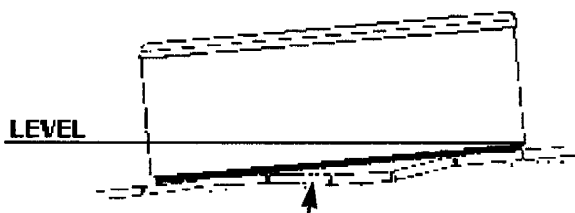

Stepping stones or brick may settle causing the spa to be unlevel.

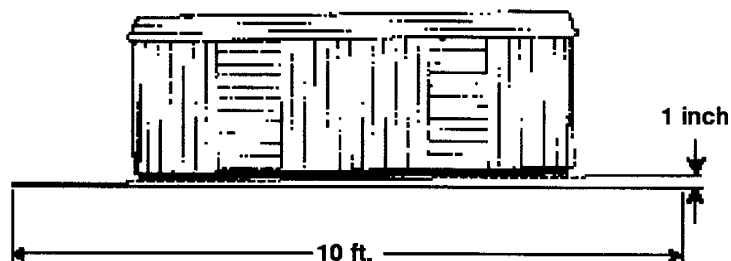

Slope 1 inch per 10 ft. for proper drainage.

It is important to note that soft surfaces, even when stepping stones are used to evenly distribute the weight of the spa, will have a tendency to settle, thus resulting in an unlevel spa.

NOTE: Placing the spa on grass or dirt may increase the amount of debris which is inadvertently brought into the spa water and may cause harm to your equipment as well as the spa surface, and is not covered under warranty.



Watkins Manufacturing Corporation recommends that the Caldera Spa be installed above ground. Lowering the top of the spa to ground level, or employing decking which raises standing level toward the top of the spa substantially increases the hazard of accidental entry. Consult a licensed building contractor to design or evaluate your custom decking requirements.

ELECTRICAL INSTALLATION

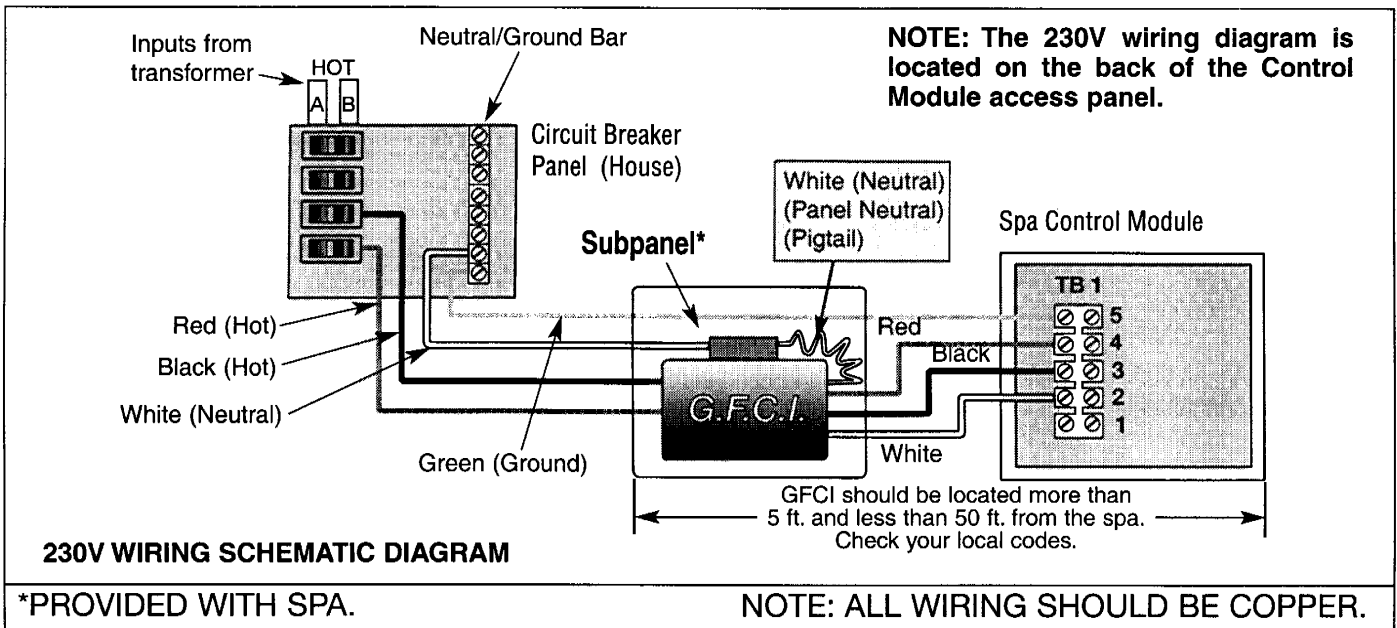

230 VOLT INSTALLATION

Your spa contains a Control Module designed to operate at 230V, 60Hz. Installation of a 50 amp. dedicated circuit is required. The Control Module must be hard wired directly to a supply circuit that is protected by a Ground Fault Circuit Interrupter (GFCI).

IMPORTANT NOTE: All electrical connections to the control Module must be accomplished by a qualified electrician in accordance with the National Electrical Code and in accordance with any local electrical codes in effect at the time and place of installation.

All electrical connections must be made in accordance with the wiring information contained in this manual and on the back of the field wiring access panel of the Control Module.

For all permanently connected units not provided with integral disconnecting means: The electrical supply for this product must include a suitable rated switch or circuit breaker to open all ungrounded supply conductors to comply with local and national Electrical Codes. The disconnecting means must be within sight, and readily accessible to the user of the spa, but installed at least 5 feet (1.5m) from the spa.

The Control Module requires an 8 AWG copper, four-wire electrical service (Line 1, Line 2, Neutral and Ground), and requires a minimum supply conductor ampacity of 50 amperes. Failure to connect a neutral line will cause the Control Module to malfunction and will void the Control Module warranty.

POWER CONNECTION

To connect power to the spa, refer to "230 VOLT WIRING SCHEMATIC DIAGRAM" and "POWER CONNECTION ACCESS" illustrations above, then proceed with the following steps:

1. Remove the screws securing the equipment compartment door and remove the door.
2. Remove the screws securing the Control Module wiring access panel and remove the panel to allow access to the input power wiring.

NOTE: The 230V wiring diagram is located on the inside of the Control Module access door.

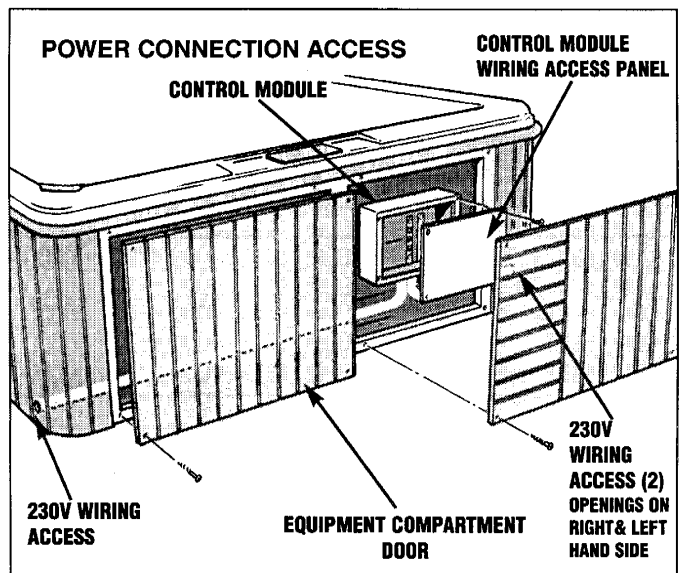

START-UP AND REFILL PROCEDURES

Your Caldera™ Spa has been thoroughly tested during the manufacturing process to ensure reliability and long-term customer satisfaction. A small amount of water may have remained in the plumbing after testing and, as a result, may have spotted the spa shell or the spa siding prior to delivery. Before filling the spa, clear all debris from the spa and wipe the spa shell clean with a soft rag.

THE FOLLOWING INSTRUCTIONS MUST BE READ AND FOLLOWED EXACTLY TO ENSURE A SUCCESSFUL START-UP OR REFILL.

CAUTIONS

- Do not fill the spa with hot water, as tripping of the high-limit thermostat may result.
 - Do not connect power to an empty spa. Power to the spa automatically activates critical components within the spa, such as Controls, Heater, Circulation Pump and other systems. If power is supplied to these components prior to the spa being filled, the components will be damaged, and this may result in a non-warranty component failure.
 - Do not use your spa after filling until all of the steps listed below are completed.
 - Do not add chlorine if treating your spa with polyhexamethylene biguanide (Biguanide, PHMB, eg. BaquaSpa™) sanitizer.
 - Before filling your spa for the first time, remove the equipment compartment doors and check to ensure that the unions on either side of the pump and heater are hand-tight. Also, install the pump's drain plug if necessary by screwing the plug into the threaded hole in the face of the pump. (The drain plug is removed for shipping in the winter months. If your drain plug is not present, a notice will be found attached to the control box, and the plug will be found in your Owner's Packet.)
1. Close all drains and fill the spa with water by removing the skimmer basket, weir and filter. Then insert the end of a garden hose into the filter hole and begin filling the spa. The water level of your Caldera™ Spa should be maintained at a level one inch above the highest jet in the spa. Reinstall the skimmer basket, weir and filter once the spa is filled.
IMPORTANT: Watkins Manufacturing Corporation does not recommend that the spa be filled with "softened" water, as this may damage the spa's equipment.
 2. **AFTER** the spa has been filled with water and the equipment compartment door is secured, power must be applied to the spa.
 - Activate power to the subpanel from the main house panel first.
 - Open the door of the electrical subpanel and reset the GFCI breaker. Close and secure the subpanel door.
 3. The jet pump(s), heating system and all internal plumbing will achieve a partial prime as the spa is filled. Sixty seconds after power is applied to the spa, the air blower will activate for 30 seconds, followed by Jet Pump 2 (except for Kauai and Martinique) for sixty seconds, followed by Jet Pump 1 for ten minutes. Once the jet system is fully operational (as indicated by strong, non-surgings jets), priming of the spa is complete. If you do not feel a steady stream of water from your jets, refer to the instructions for priming the pump in the SPA TROUBLESHOOTING section in the back of this manual.
IMPORTANT: Be sure that the air control valves are open by turning each one counterclockwise and checking to see that all the diverters are in position 1 or position 3 (see illustration on air control and diverter valves).
 4. Adjust Total Alkalinity (TA) to 125 ppm, Calcium Hardness (CH) to 150 ppm, then spa water pH to between 7.2 and 7.4. These procedures are listed in the "Water Quality and Maintenance" section.
IMPORTANT: Add spa water chemicals directly into the filter compartment with the jet pump on for at least ten minutes (use cleanup cycle) by depressing # followed by the **Jets 1** button on the main panel.
OPERATION NOTE: Adjusting the Total Alkalinity as the first step is important, as out-of balance TA will affect your ability to adjust the pH correctly and will prevent the sanitizer from operating effectively.
 5. Superchlorinate the spa water by adding 1-1/2 teaspoons of chlorine (sodium dichlor) per 250 gallons of spa water. The jet pump should be running when adding the chlorine, and remain on to circulate the spa water for a ten-minute period (use cleanup cycle). Make sure all the diverter valves are set to position 2 (combo or middle position).
 6. Set the temperature control to the desired temperature (between 100°F and 104°F), then place the thermal cover on the spa and allow the water temperature to stabilize (approximately 24 hours). Make sure you secure the cover in place using the cover locks. Periodically check the spa water temperature. When the water temperature climbs above 90°F, proceed to the next step.
 7. Press # followed by the **Jets 1** button on the main control panel and run the pump for 10 minutes to circulate the spa water. Make sure all the diverter valves are set to position 2 (combo or middle position). Once the jets shut off, test the spa water for Free Available Chlorine (FAC) residual. If the residual is between 3 and 5 ppm on the test strips (found in the test kit) go on to the next step. If the residual is less than 3 ppm, superchlorinate the spa water by adding 1-1/2 teaspoons of chlorine (sodium dichlor) per 250 gallons of spa water, while the jet pump is running. Run the jet pump to circulate the spa water for an additional ten-minute period.
 8. Recheck the Total Alkalinity (TA) at 125 ppm, Calcium Hardness (CH) at 150 ppm, then spa water pH at between 7.2 and 7.4.
OPERATION NOTE: Make sure you adjust your Total Alkalinity first, as an out-of-balance condition will affect your ability to adjust the pH correctly, and will prevent the sanitizer from operating effectively. **The spa is ready for use when the spa water has circulated and the chlorine level remains between 3 ppm and 5 ppm.**
 9. The spa temperature is pre-programmed to reach 100°F, and will normally do so within 18 to 24 hours. You may raise the water temperature by pressing the **Warm** button on the control panel once to display the temperature, then pressing it again within 5 seconds to raise the temperature, or lower it by pressing **Cool** button once to display the temperature, then pressing it again within 5 seconds to lower the temperature. After a few hours, the water temperature will remain within 1-1/2 degrees of your selected temperature.

SPA COVER INSTALLATION

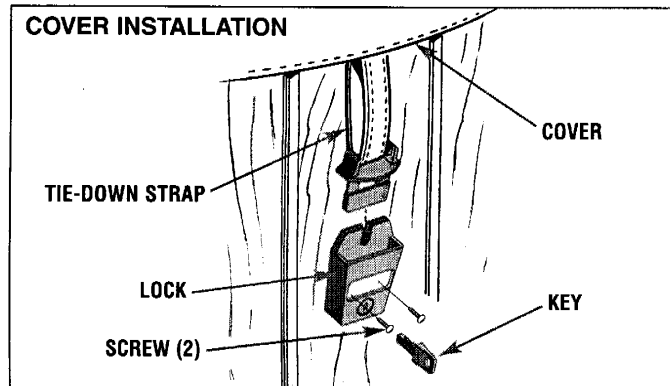

- Place the cover squarely on the spa.
- Position the tie-down locks included with your cover on the side of the spa so that they are easily reached by the cover tie-down straps. Allow for about 1/2" to 3/4" slack in the straps to make it easy to insert straps into locks and to compensate for vinyl shrinkage in cold weather.
- Attach the locks with the screws provided and insert the cover tie-down straps into the locks.

Keeping the cover in place any time the spa is not in use will reduce the amount of time the heater operates, thereby minimizing operating costs.

DANGER. RISK OF INJURY.

- **Never leave a spa uncovered or unattended.**
- **Never leave a spa cover unlocked.**
- **Do not stand, sit or lie on the cover.**

CUSTOMIZING YOUR MASSAGE

Your Caldera spa offers numerous ways for you to customize your massage experience. Experimentation is the best way to find what feels best to you. Try sitting in different seats, adjusting the diverter valves, air controls and jet nozzles and turning each pump on or off.

DIVERTER VALVES

The diverter valves on your spa allow you to direct the flow of water from the pumps to various combinations of jets. The functions of these diverter valves can best be learned by experimentation as follows:

1. Set all air controls to the "MAX" position.
2. Turn on both pumps (except Martinique and Kauai).
3. Turn the handle on each diverter valve and see which groups of jets are affected. (Note that you can adjust the diverter valves to any position between the two possible extremes to achieve the jet pressure that feels best to you.)

IMPORTANT: Your spa is not designed to provide full power to all jets when the diverter valves are in the "Combo" position. However, with the diverter valve in this position, you may increase the power to selected jets by rotating the face of the Magna and MagnaSsage jets to close the ones that are not in use.

TIP: Turn both pumps on and position the diverter valves to "Combo". Then experiment with each of the air controls to see their effect.

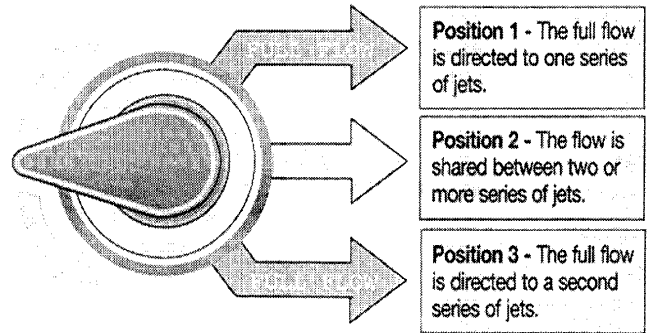

AIR CONTROLS

Each jet system has its own air control. These allow you to change the power of the jets by regulating the amount of air that is mixed with the water coming out of the jets.

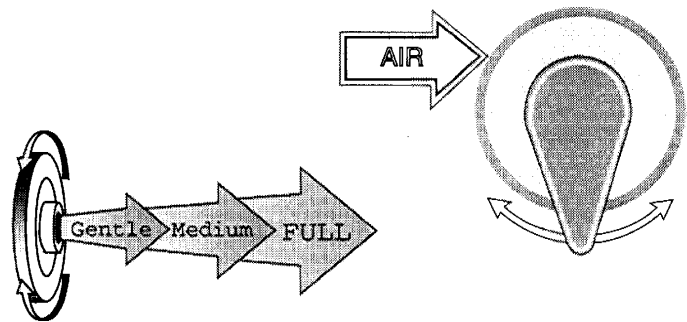

HYDRO JETS

Magna Jets - These jets allow you to re-direct the jet stream by changing the position of the nozzle.

MagnaSsage Jets - These jets provide a rotating massage pattern.

The nozzles in the Magna jets and the MagnaSsage jets are interchangeable. To remove a MagnaSsage rotating nozzle, simply grasp it and pull straight out. To install, align and push straight in, the nozzle will snap into place. To remove or install a standard Magna jet nozzle, rotate the tabs on either side of the nozzle. Additional MagnaSsage rotating nozzles and dual-port nozzles are available from your Caldera dealer.

Both the Magna and MagnaSsage jets allow you to regulate the force of the massage. Rotate the fascia ring clockwise to reduce the force or counter-clockwise to increase the force. Notice that turning off the flow to some jets increases the flow to the other jets. To avoid damage to your spa's plumbing and components, do not turn off more than half of these jets at the same time.

Euro and Euro-Pulse Jets - The small Euro jets deliver a direct, precise massage. Many of these jets feature a special insert that creates a soft, pulsating, rotary massage. The roto jet cap assemblies may be removed if you want a more powerful, direct massage in a particular location. To do this, gently pry around the outside edge of the cap assembly with a table knife, screwdriver or similar tool. If you desire, you may install a roto jet cap removed from one jet onto a standard euro jet simply by snapping the assembly into place. You may purchase additional roto jet assemblies from your Caldera dealer.



Versa Jets - The direction of the water stream can be redirected by repositioning the nozzle. You may convert any Versa jet to a VersaSsage jet with a replacement nozzle available from your Caldera dealer.

VersaSsage Jets - These jets may be adjusted to provide either a stationary, direct stream, or, by positioning the nozzle to one side or the other, a variety of rotating massage patterns.



AIR JETS

The Air jet system consists of a 1 HP Air pump and 10 Air jets. At the beginning of the automatic operation cycle, the Air jets will operate for 30 seconds to clean out the air channel. The air jets deliver air bubbles to provide a subtle pulsation for gentle, soft-tissue massage.



GENEVA PARADISE JET MENU

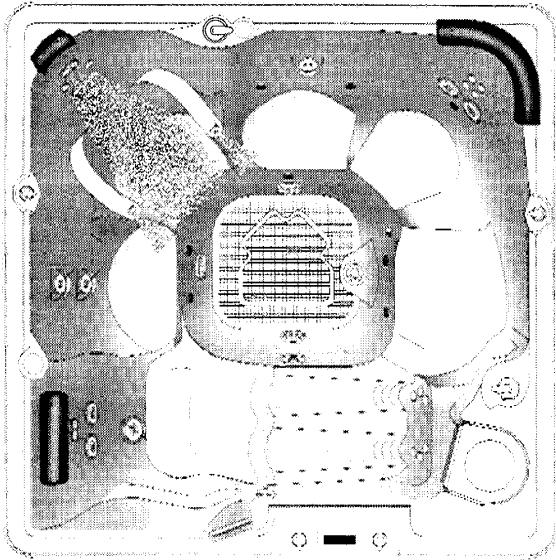

Back Jet Pump-Jet System 1

Located in EcstaSeat™ – back left

- 6 Euro-Pulse jets
- 6 Euro jets

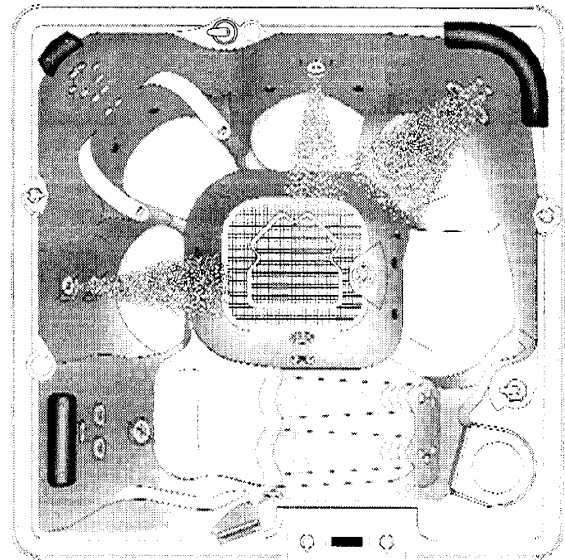

Back Jet Pump-Jet System 3

- 2 MagnaSsage jets on left wall
- 1 Magna jet on back wall

Located in Lumbar Massage™ seat – back right

- 4 Euro jets
- 2 Versa jets

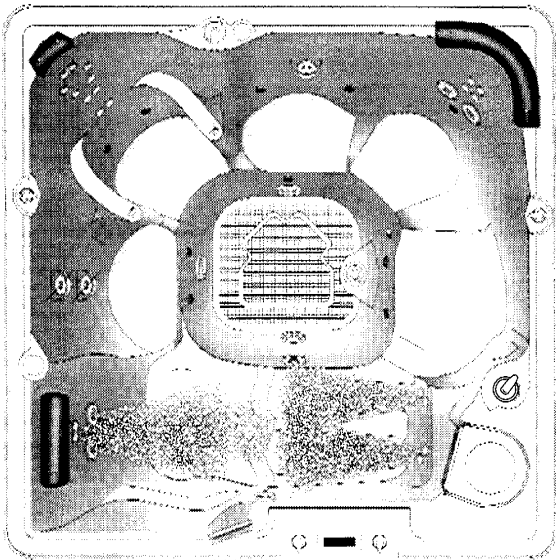

Front Jet Pump-Jet System 1

Located in Ultra Massage™ lounge – front

- 6 Sole Soothers
- 2 Euro-Pulse jets
- 2 Versa jets
- 1 VersaSsage jet

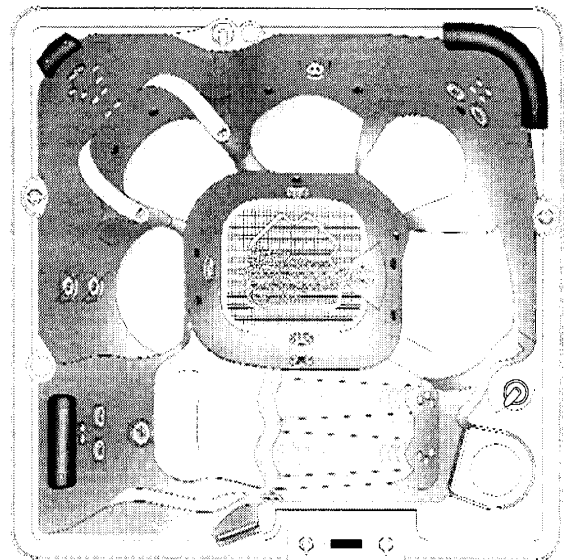

Front Jet Pump-Jet System 3

- 1 Euphoria jet in footwell

Jet System 2

Back Jet Pump diverter position 2 activates both Back Jet Pump Systems 1 and 3.
Front Jet Pump diverter position 2 activates both Front Jet Pump Systems 1 and 3.

NIAGARA PARADISE JET MENU

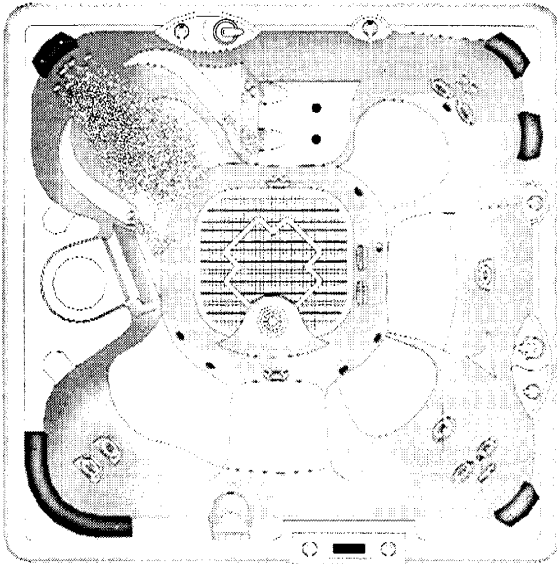

Back Jet Pump-Jet System 1

Located in EcstaSeat™ – back left

- 6 Euro-Pulse jets
- 6 Euro jets

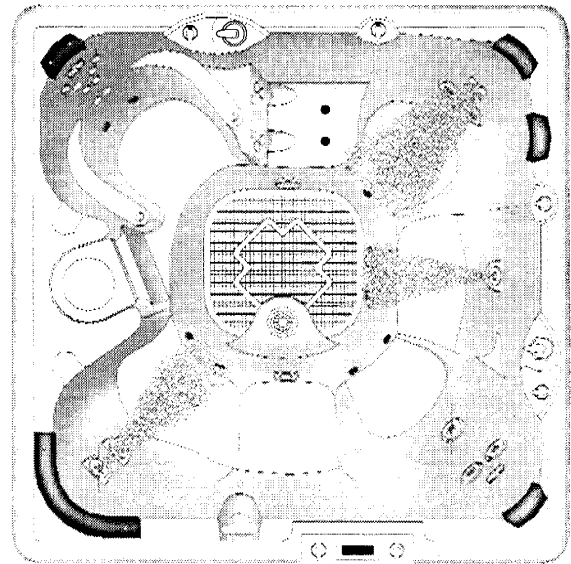

Back Jet Pump-Jet System 3

- 1 Magna jet on rightwall
- 2 Versa jets on front left wall

Located in Lumbar Massage™ seat – back right

- 4 Euro jets
- 2 Versa jets

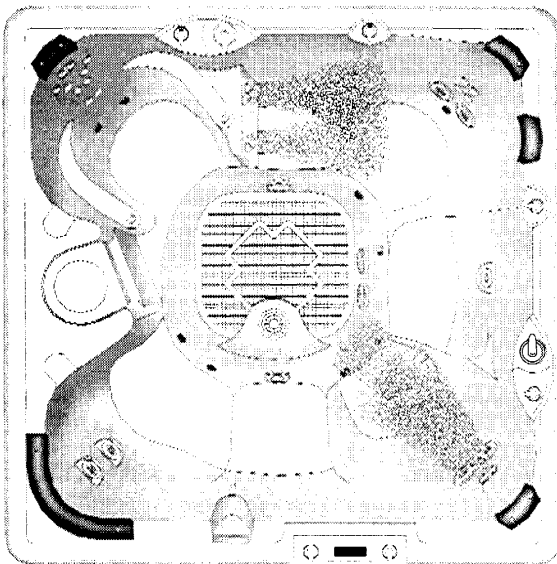

Front Jet Pump-Jet System 1

- 6 Sole Soothers in back center

Located in Ultra Massage™ seat – front right

- 2 Euro-Pulse jets
- 2 Versa jets
- 1 VersaSsage jet

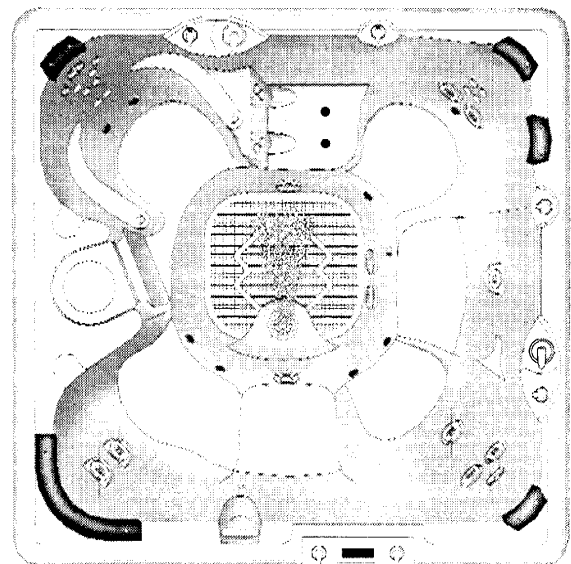

Front Jet Pump-Jet System 3

- 1 Euphoria jet in footwell

Jet System 2

Back Jet Pump diverter position 2 activates both Back Jet Pump Systems 1 and 3.
Front Jet Pump diverter position 2 activates both Front Jet Pump Systems 1 and 3.

HAWAIIAN PARADISE JET MENU

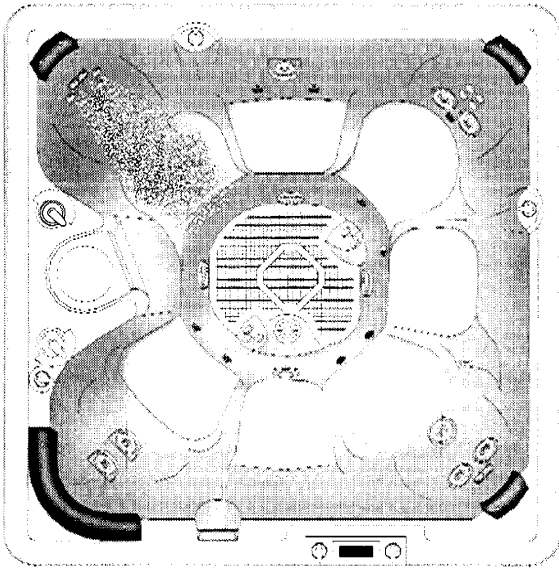

Back Jet Pump-Jet System 1

Located in EcstaSeat™ – back left

- 4 Euro-Pulse jets
- 6 Euro jets

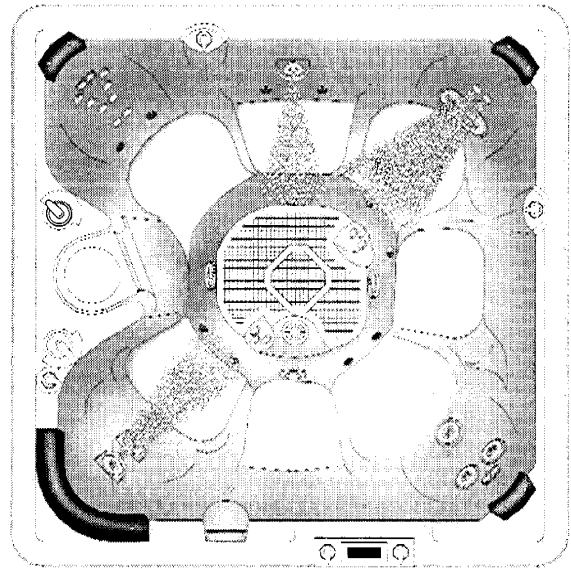

Back Jet Pump-Jet System 3

- 1 Magna jet on back wall
- 2 VersaSage jets on front left wall

Located in Lumbar Massage™ seat – back right

- 4 Euro jets
- 2 Versa jets

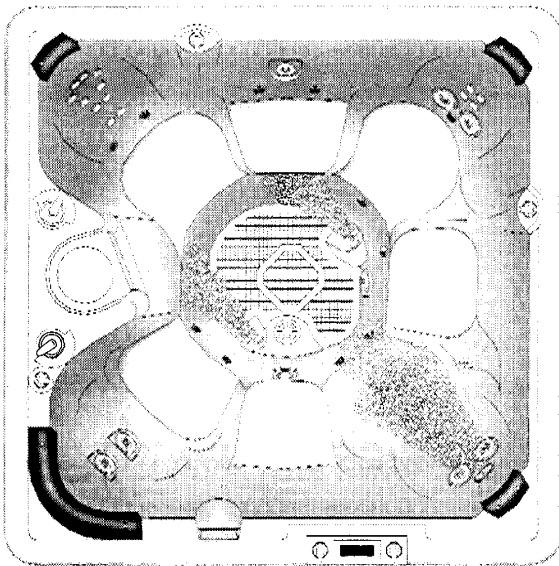

Front Jet Pump-Jet System 1

- 6 Sole Soothers in footwell

Located in Ultra Massage™ seat – front right

- 2 Euro-Pulse jets
- 2 Versa jets
- 1 VersaSage jet

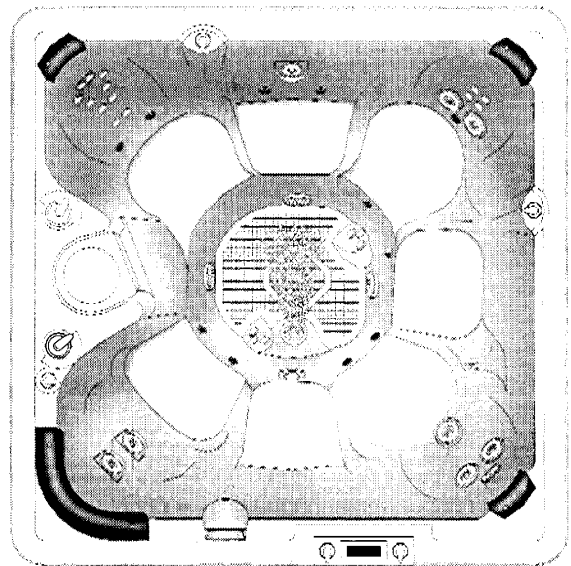

Front Jet Pump-Jet System 3

- 1 Euphoria jet in footwell

Jet System 2

Back Jet Pump diverter position 2 activates both Back Jet Pump Systems 1 and 3.
Front Jet Pump diverter position 2 activates both Front Jet Pump Systems 1 and 3.

TAHITIAN PARADISE JET MENU

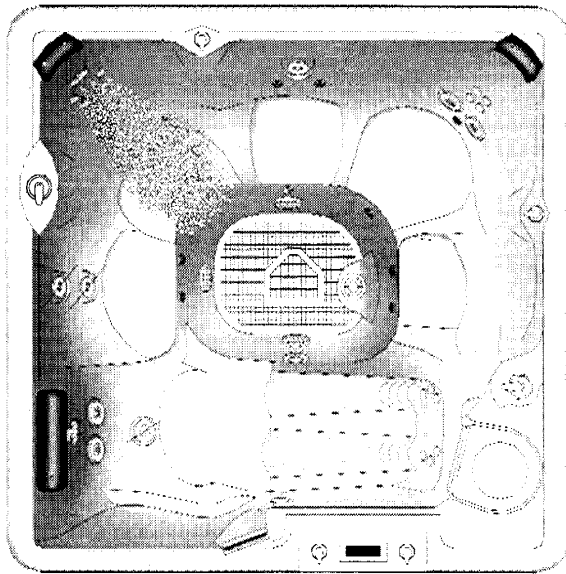

Back Jet Pump-Jet System 1

Located in EcstaSeat™ – back left

- 4 Euro-Pulse jets
- 6 Euro jets

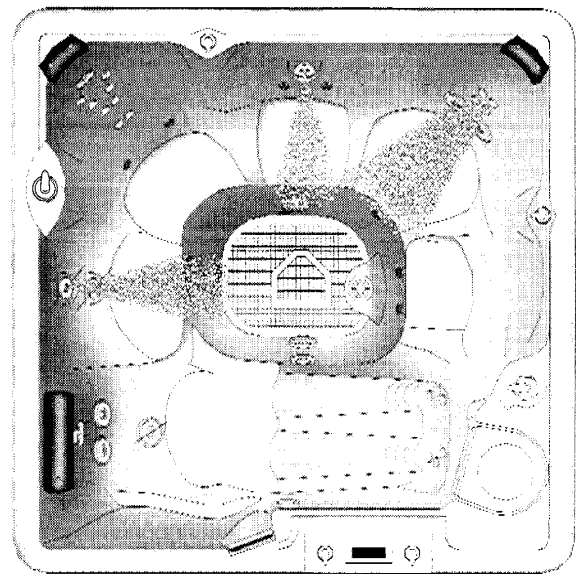

Back Jet Pump-Jet System 3

- 2 MagnaSsage jet on left wall
- 1 Magna jet on back wall

Located in Lumbar Massage™ seat – back right

- 4 Euro jets
- 2 Versa jets

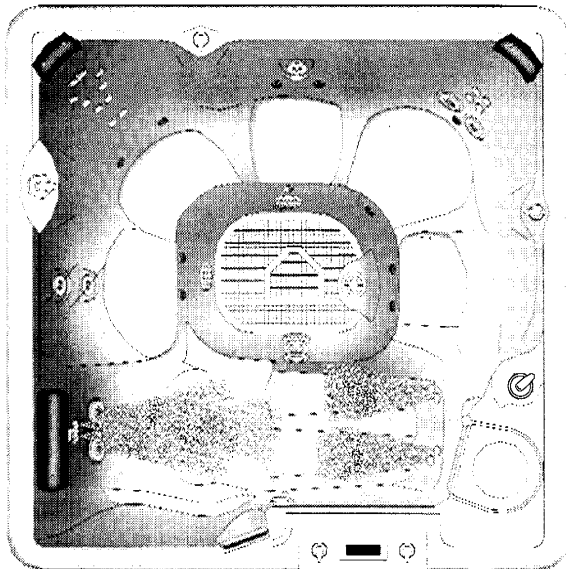

Front Jet Pump-Jet System 1

Located in Ultra Massage™ seat – front

- 6 Sole Soothers
- 2 Euro-Pulse jets
- 2 Versa jets
- 1 VersaSsage jet

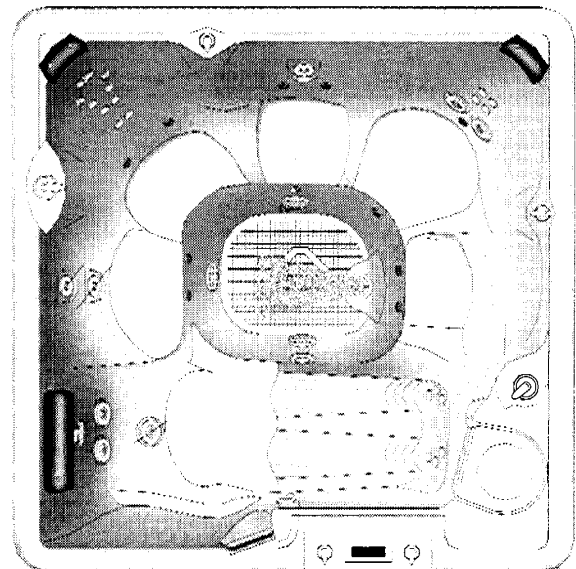

Front Jet Pump-Jet System 3

- 1 Euphoria jet in footwell

Jet System 2

Back Jet Pump diverter position 2 activates both Back Jet Pump Systems 1 and 3.
Front Jet Pump diverter position 2 activates both Front Jet Pump Systems 1 and 3.

MARTINIQUE PARADISE JET MENU

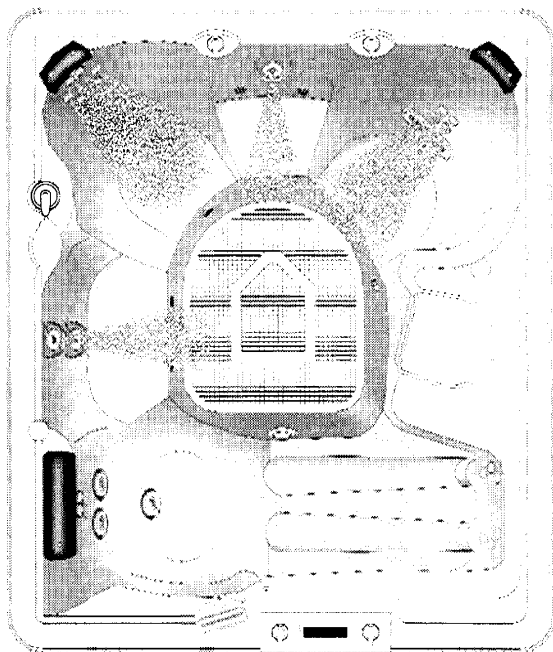

Jet Pump-Jet System 1

- 1 Magna jet on back wall
 - 2 MagnaSsage jets on left wall
- Located in EcstaSeat™ – back left
- 4 Euro-Pulse jets
 - 4 Euro jets
- Located in Lumbar Massage™ seat – back right
- 4 Euro jets
 - 2 Versa jets

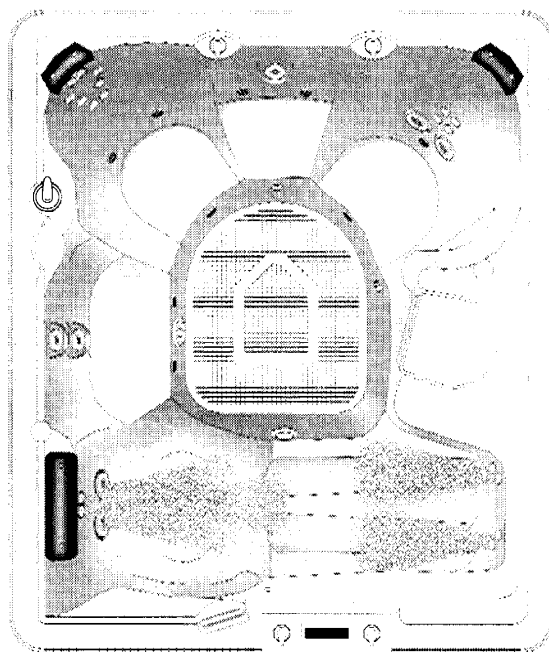

Jet Pump-Jet System 3

- Located in Ultra Massage™ lounge – front
- 6 Sole Soothers
 - 2 Euro-Pulse jets
 - 2 Versa jets
 - 1 VersaSsage jet

Jet System 2

Jet Pump diverter position 2 activates both Back Jet Pump Systems 1 and 3.

KAUAI PARADISE JET MENU

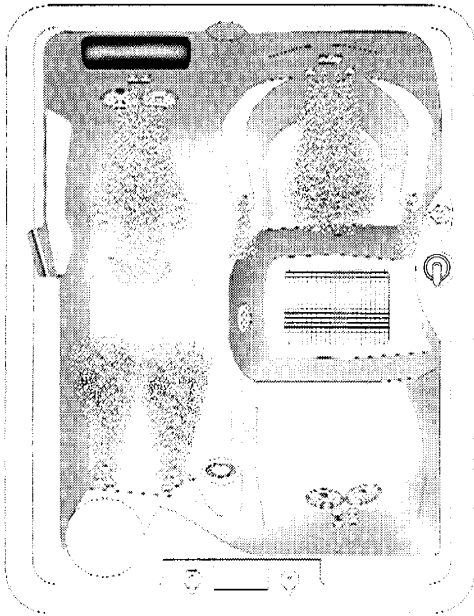

Jet Pump-Jet System 1

Located in Ultra Massage™ lounge

- 6 Sole Soothers
- 2 Euro-Pulse jets
- 2 Versa jets
- 1 VersaSsage jet

Located in EcstaSeat™

- 6 Euro-Pulse jets
- 4 Euro jets

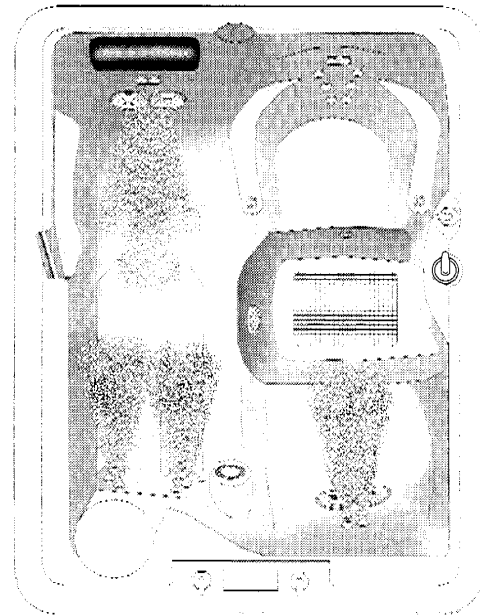

Jet Pump-Jet System 3

Located in Ultra Massage™ lounge

- 6 Sole Soothers
- 2 Euro-Pulse jets
- 2 Versa jets
- 1 VersaSsage jet

Located in Lumbar Massage™ lounge

- 4 Euro jets
- 2 Versa jets

Jet System 2

Jet Pump diverter position 2 activates both Back Jet Pump Systems 1 and 3.

OPERATING INSTRUCTIONS

Mode touch pad Is used to initiate advanced panel features

LIGHT touch pad
Controls the 3-way Mood Light or Interior Fiber Optic Lighting (Optional)

JETS touch pads Controls Jet pumps 1 and 2

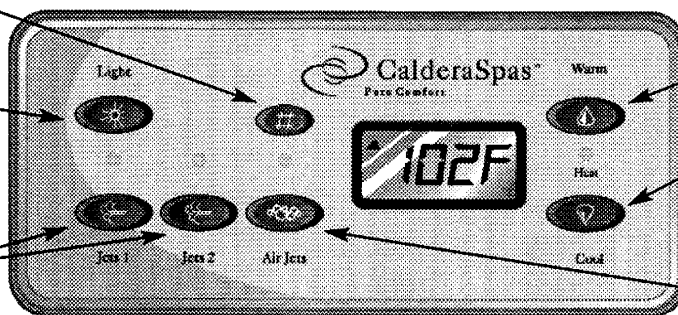

WARM (up) touch pad
Increases the temperature

COOL (down) touch pad
Decreases the temperature setting

AIR JETS touch pad
Controls the Air Jets

Geneva • Niagara • Tahitian • Hawaiian

Mode touch pad Is used to initiate advanced panel features

LIGHT touch pad
Controls the 3-way Mood Light or Interior Fiber Optic Lighting (Optional)

JETS touch pad Controls the Jet pump

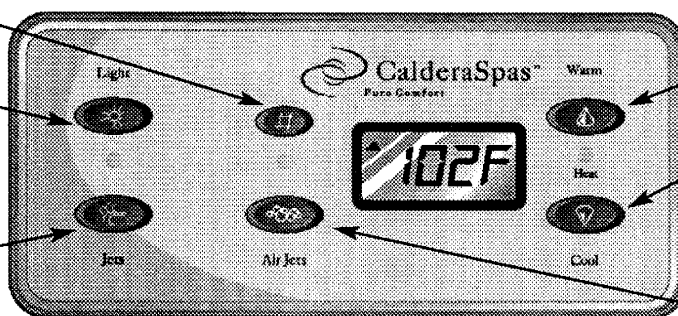

WARM (up) touch pad
Increases the temperature

COOL (down) touch pad
Decreases the temperature setting

AIR JETS touch pad
Controls the Air Jets (Martinique only)

Martinique • Kauai

LOCKING FEATURES

The two locking features, TEMPERATURE LOCK and SPA LOCK, are enabled from the control panel by pressing a specific combination of buttons. Once enabled, a lock will remain active until the specific button combination is applied to disable the lock. Even if power is disconnected from the spa and soon thereafter reappplied (such as after a power outage), the lock will remain in place.

Spa Lock

The Spa Lock feature deactivates all of the functions of the control panel. It is generally used to prevent unwanted use of the spa.

To activate the Spa Lock, press + + within 3 seconds.

To deactivate the Spa Lock, press + + within 3 seconds.

Temperature Lock

The Temperature Lock feature deactivates the temperature control function from the control panel. All other functions on the control panel will operate normally. Temperature Lock is most often used by those who do not want others to change the set temperature of the spa water.

To activate the Temperature Lock, press or + + + within 3 seconds.

To deactivate the Temperature Lock, press or + + + within 3 seconds.

Control Panel Buttons and Display

Your spa control system consists of an illuminated Liquid Crystal Display (LCD) and convenient touch pads that allow you to set the water temperature as well as the hydrotherapy jets, mood light and optional jets from the spa control panel.

Display Inversion

You may invert the main, four-digit display for easier viewing from inside the spa. Press either or then within 3 seconds.

Temperature Control

The set temperature range is from 80°F to 104°F (the temperature of any setting may rise slightly depending on the current use and condition of your spa, and on outside temperature).

The set temperature of the spa water will automatically be 100°F the first time power is applied. This is the setting programmed at the factory. After the spa has been set up and used, the last temperature value set by the user will be stored in memory. If power is disconnected from the spa, it will automatically revert to the last set temperature when power is reapplied.

OPERATING INSTRUCTIONS

To display the set temperature for three seconds, press either WARM or COOL. To change the set temperature while the set temperature is displayed, press WARM to increase or COOL to decrease the set temperature. An LED between the WARM and COOL buttons will illuminate whenever the heater is activated.

Jets Control

Pressing the Jets button (on the Kauai or Martinique) or the Jets 1 or Jets 2 button (Geneva, Niagara, Tahitian or Hawaiian) turns the single speed pump on or off. An LED above the Jets button will illuminate whenever the Jets button is activated. The pumps automatically turn off after operating for 30 minutes.

Air Jets Control



Press the Air Jets button to start or stop the air jets. The air jets operate for 15 minutes, then automatically shut off. An LED above the Air Jets button will illuminate whenever the Air Jets button is activated.

Light Control (Mood Light Only)

The Light button allows you to select from three different settings. Press the light button once to turn on the brightest setting. Press a second time to turn on the intermediate setting, and again for the dimmest setting. Press the touch pad a fourth time to turn off the light. The light automatically turns off after 4 hours of operation.

Light Control (Interior Fiber Optic – Optional)

If your spa is equipped with the aftermarket interior spa fiber optic system, the light button operates the fiber optic light as follows:

- Press  once to turn on the light and rotate the color wheel.
- Press  again to turn off the rotating color wheel while the light remains on.
- Then press  a third time to shut both the light and color wheel off.

The light automatically turns off after 6 hours of operation.

Advance Mode Control

The Mode button is used to initiate advanced panel features such as the cleanup cycle, panel lock, temperature lock, and setting the automatic fiber optic light (optional).

AUTOMATIC OPERATIONS

System Purge

The system purge operates in the following manner:

- The air blower activates for 30 seconds.
- Jet Pump 2 runs for 1 minute (on Geneva, Niagara, Tahitian, and Hawaiian models only).
- Jet Pump 1 runs for 10 minutes.

This system is initiated 60 seconds after the spa is powered up, then operates once per day.



Summer Logic

The circulation pump, heater and ozone are disabled if the temperature regulating system detects that the water temperature exceeds the set temperature by 5 degrees. The circulation pump, heater and ozone will remain disabled for the next 8 hours. After 8 hours, the functions will be enabled and remain active for the next 16 hours. Upon completion of a 24 hour period the temperature regulating system will again compare the water temperature with the set temperature to determine if the cycle should repeat.

Auto Heat



The heater will automatically activate if the water temperature is 20°F below the set temperature.

Interior Fiber Optic Light (Optional)

If your spa is equipped with the fiber optic light, it may be set to automatically come on for 6 hours every day. You must wait until the desired starting time before activating the automatic mode. To activate the automatic mode, press  +  +  within 3 seconds. This will cause the fiber optic light to illuminate for 6 hours every night at the same time. To deactivate the automatic function simply press the same buttons again.

NOTE: Automatic fiber optic light is not enabled on power-up.

Cleanup Cycle

The cleanup cycle (used for water maintenance) will activate Jet Pump 1, run for ten minutes, then automatically shut off. To activate the cleanup cycle, press  +  within 3 seconds.

EQUIPMENT COMPARTMENT (JET PUMP SIDE)

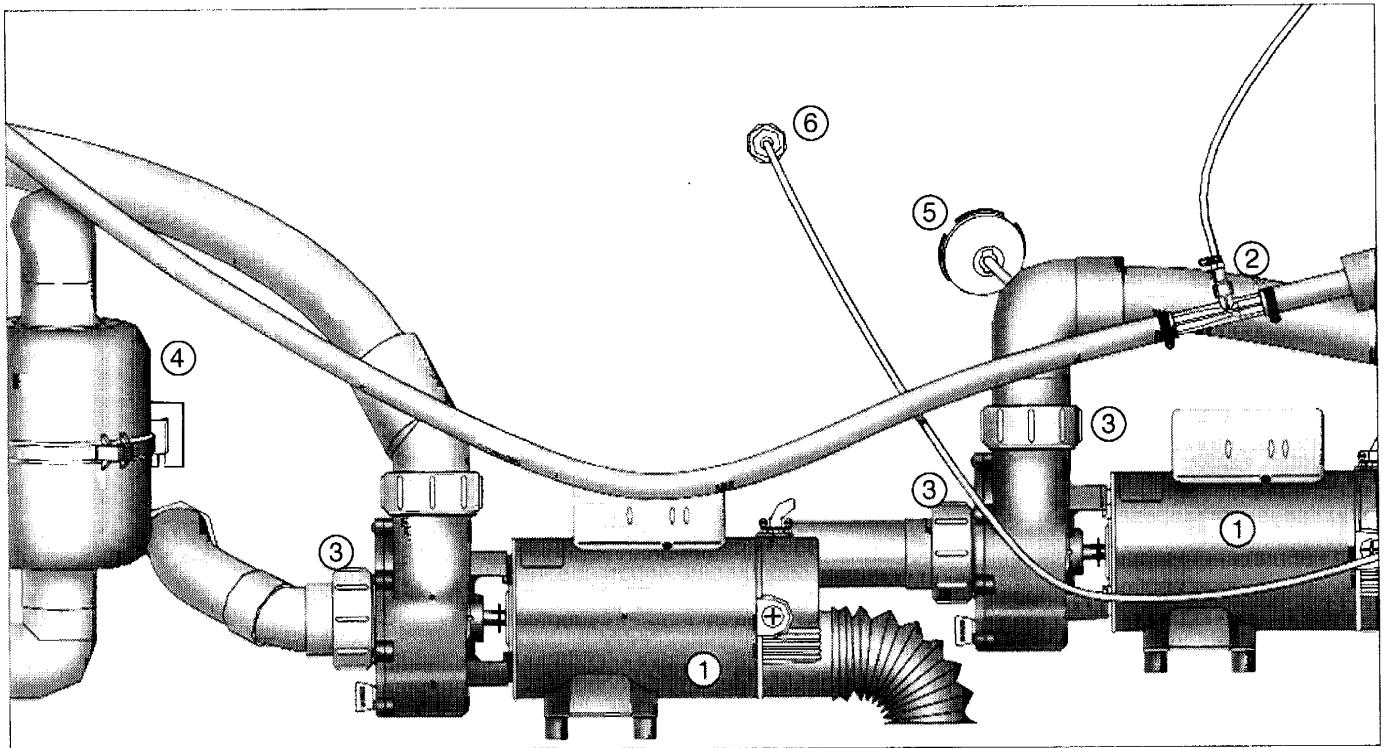

Geneva, Niagara, Tahitian and Hawaiian

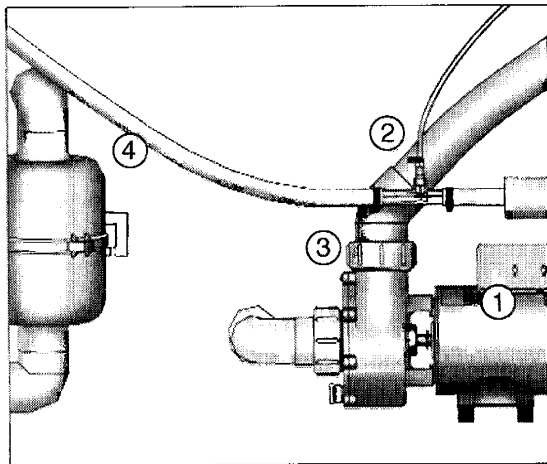

Martinique

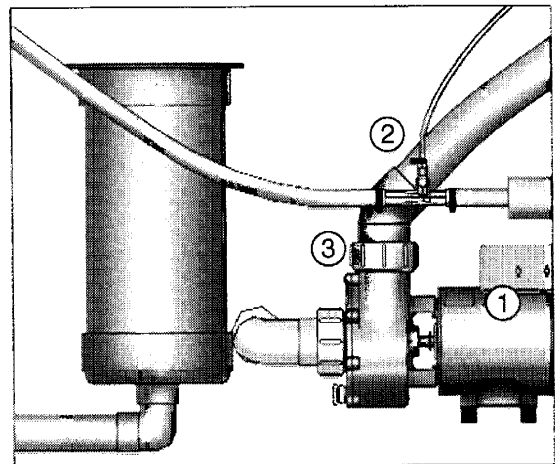

Kauai

1. Jet Pump
2. Ozone Injector (Optional)
3. Unions
4. Air Pump
5. Light
6. Thermostat

EQUIPMENT COMPARTMENT (CONTROLS SIDE)

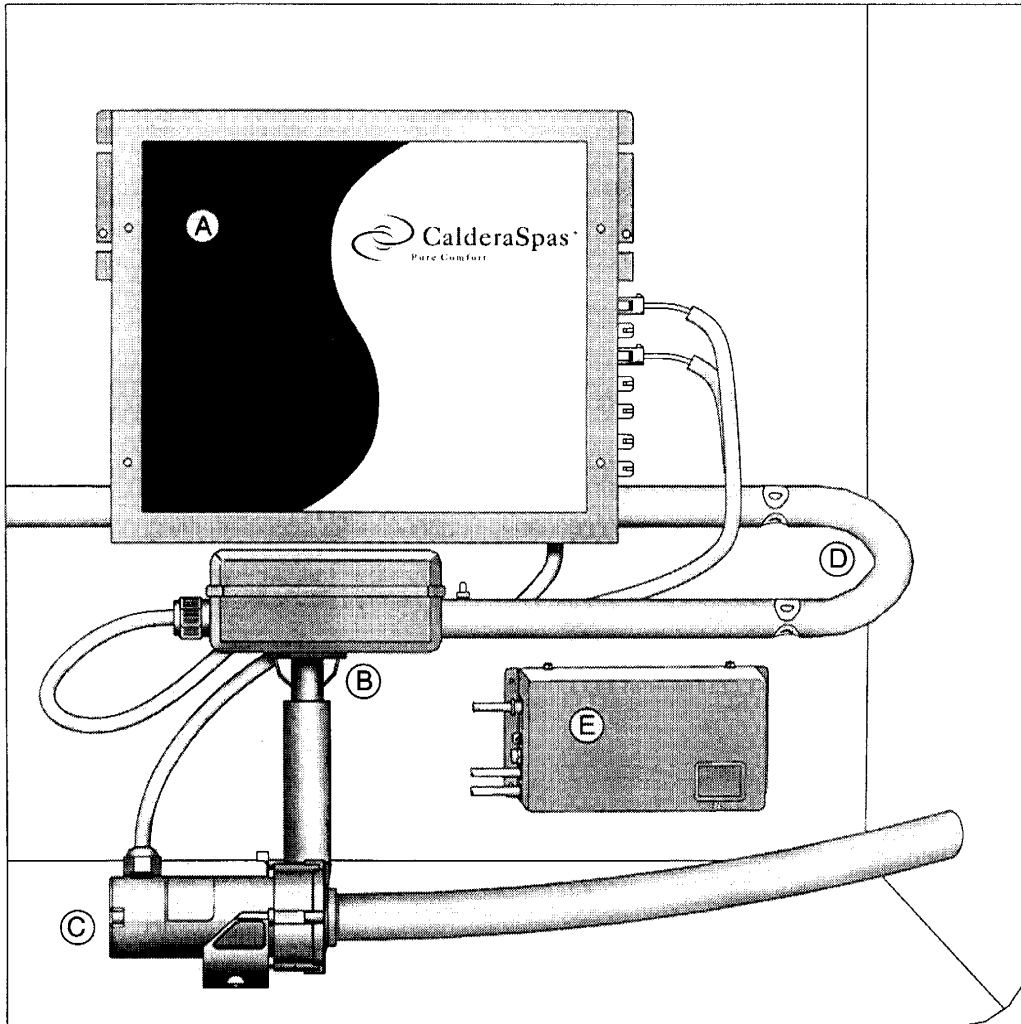

- A. Control Box
- B. Pressure Switch
- C. Circulating Pump
- D. Low Flow Heater
- E. Caldera Ozone System (Optional)

MAINTENANCE

FILTER CARTRIDGE REMOVAL AND CLEANING INSTRUCTIONS

Turn the power to the spa off, then proceed as follows:

1. Push down slightly and turn filter basket counter-clockwise to unlock, then pull the basket and weir out.
2. Carefully pull up the filter cartridge and bring it out of the spa.
3. Rinse cartridge using a garden hose. Rotate and separate filter pleats while spraying water to remove all debris possible. Let the filter dry and then look for calcium deposits (scaling) or an oil film. If you find these, you will need to deep clean your filter cartridge with a "spa filter cleaning" solution to break down and remove mineral deposits and oils.
4. To return basket and weir, insert and rotate clockwise to lock into position. Then, turn spa's power back on.

NOTE: Replacement filter cartridges are available from your Caldera dealer. Refer to the back of this manual to determine the appropriate size for your spa.

SPA LIGHT COLORED LENS INSTALLATION

Colored lenses are included with the spa light. To install or remove lens, push ON or pull OFF of the spa light.

SPA LIGHT BULB REPLACEMENT

1. Turn OFF the power to the spa.
2. Remove the equipment compartment access door.
3. Locate the rear of the spa light (see "EQUIPMENT COMPARTMENT (JET PUMP SIDE)").
4. To remove the bulb, turn it counter-clockwise 1/4 turn, and remove the bulb from the socket.
5. Replace the bulb by reversing the above steps.

CAUTION: The replacement bulb must be the same rating as the factory installed bulb (replacement part number 37-0101 Fk2, package of two; or standard automotive type #912).

DIVERTER VALVE MAINTENANCE

If your spa's diverter valves become difficult to turn, it is likely that sand or grit has become lodged inside the valve body. It is very important that this debris is removed as soon as possible to avoid damage to the valve. To accomplish this, follow this procedure:

1. Turn off power to the spa.
2. Remove the diverter valve's handle by pulling upward while rocking it back and forth.
3. Unscrew the cap ring.
4. Remove the valve body by pulling it upward.
5. Wipe the valve body and the interior walls of the valve clean.
6. Lubricate the valve body with a waterproof lubricant available from your Caldera dealer.
7. Reassemble the valve and turn on power to the spa.

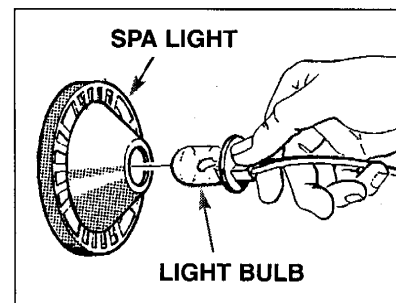
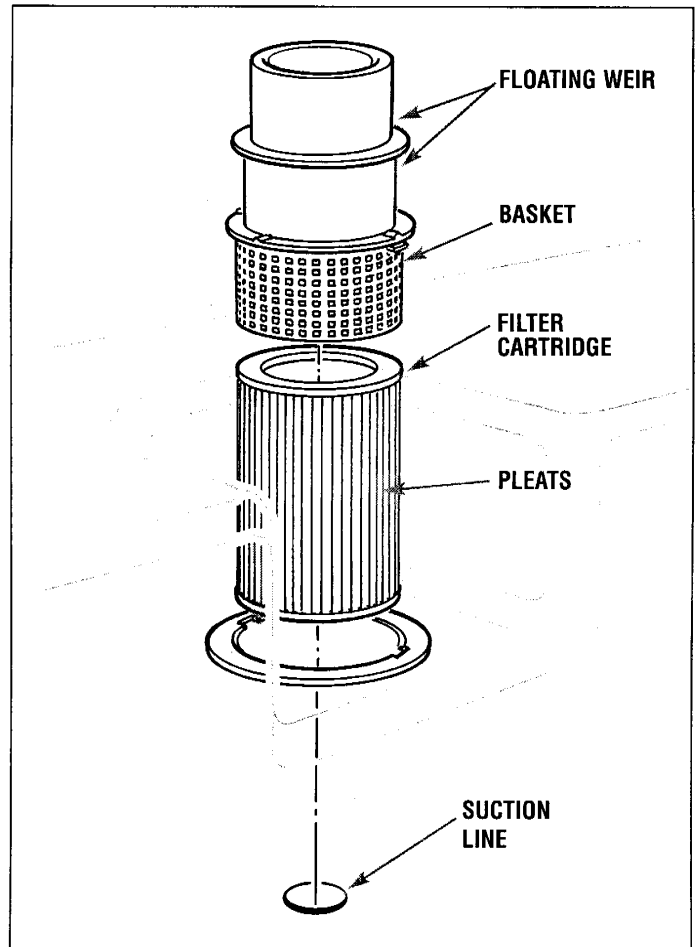

MAINTENANCE

WINTERIZING YOUR SPA

If you wish to leave your spa empty and it is located where freezing temperatures occur, follow steps 1 thru 5 outlined in "Draining your spa" then complete the following steps:

1. If your spa is equipped with the air pump, refer to "EQUIPMENT COMPARTMENT" and identify its location. If you do not have an air pump, proceed to step #4.
NOTE: Make certain all power to the spa is OFF before you continue.
2. Remove the screws securing the spa side panel and remove panel (left hand side of spa when facing the spa-side control –not the equipment compartment door).
3. Attach a shop vacuum hose to the air intake of the Air pump, then operate the shop vacuum (in blow mode) for a few seconds until all water has been removed from the air jets and air channel.

4. It will be necessary to remove all water from the interior plumbing. Remove the screws securing the drain/suction covers, then remove the suction cover by turning counterclockwise.
5. Remove the floating weir, basket and filter cartridge. Insert a shop vacuum hose into the suction line located in the bottom of the filter compartment (operate in the blow mode). If the vacuum hose does not fit tight into the opening, air will escape. It might be necessary to wrap a rag around the vacuum hose to make an air-tight seal.
6. With the vacuum blowing into the opening of the filter compartment, note that air escapes through one of the suction openings in the footwell. Close this suction opening by installing a 1-1/2" NPT "freeze plug" (available from a hardware store). Position all diverter valves to "Combo" and operate the shop vacuum in blow mode to blow all of the water out of some of the jet lines.
7. Note that there are two other suction openings in the sides of the footwell. Remove the freeze plug used in the previous step and install it in one of these openings. Insert the vacuum hose into the other suction opening and blow the water out of those jet lines.
8. Remove the freeze plug, replace the suction covers and reinstall the screws to secure the suction covers.

9. Use a wrench to remove the pump drain plugs located on the front of the pump housings. Allow all water to drain out, then replace the pump drain plugs.

NOTE: DO NOT LEAVE ANY WATER IN YOUR SPA.

WARNING: When not in use, the spa must be covered with an insulating spa cover. Damage caused by either sun exposure or freezing is not covered under warranty.

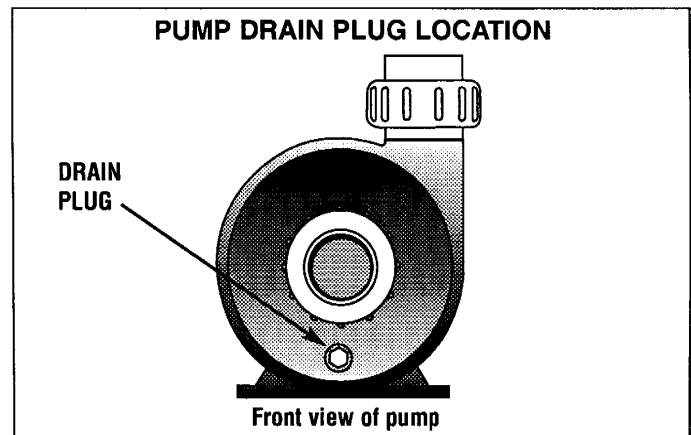
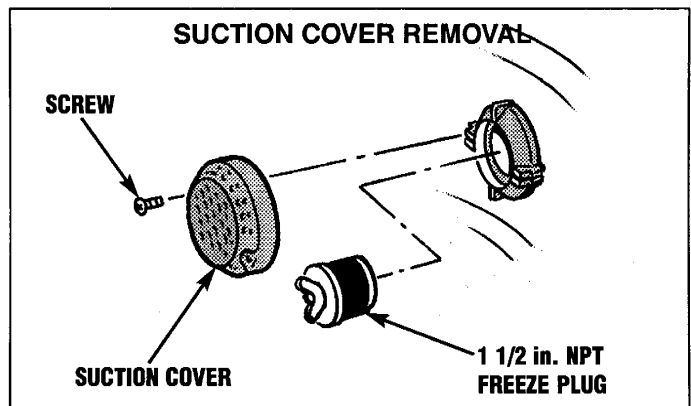
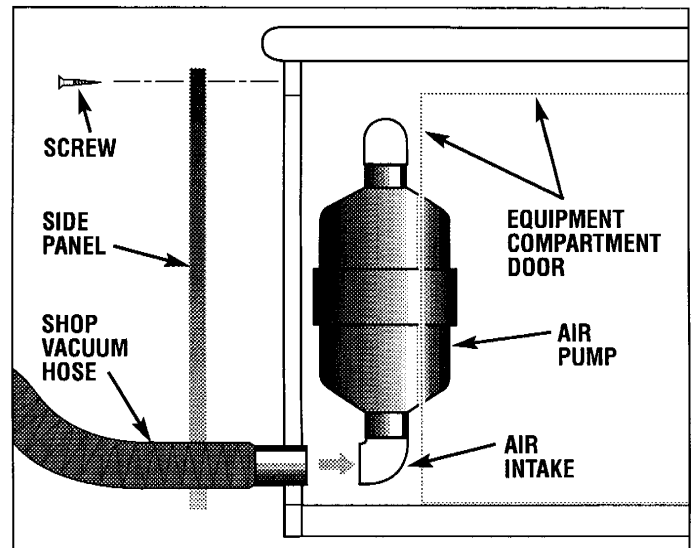

MAINTENANCE

DRAINING YOUR SPA

1. Trip all GFCI breakers in sub-panel, or main electrical panel.
2. Remove the equipment compartment access door.
3. Locate the end of the drain hose and lift it above the water level. (Requires clipping plastic tie the first time.)
4. Unscrew and remove the drain cap.
5. Attach drain hose to a garden hose and direct to an appropriate draining area, keeping the hose below the water line.
6. After your spa is empty, clean the shell and filter cartridge. See "IMPORTANT MAINTENANCE PROCEDURES".
7. After cleaning, remove garden hose, replace drain cap and put drain hose back in equipment compartment.
8. Follow the "START-UP AND REFILL PROCEDURES" to refill your spa.

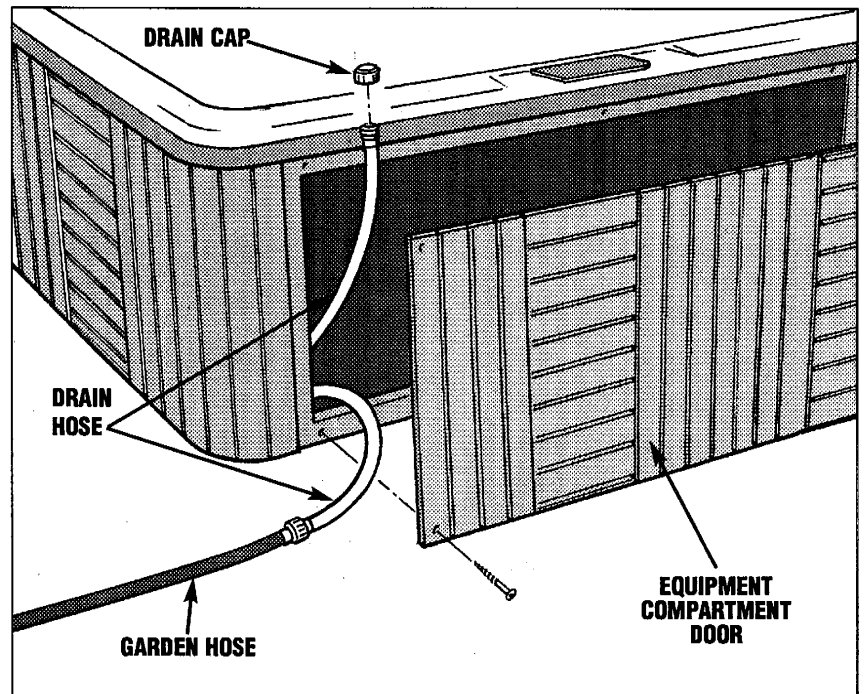

MAINTENANCE

CARE OF THE SPA PILLOWS

The spa pillows will provide years of comfort if treated with care. They have been positioned above the water level to minimize the bleaching effects of chlorinated water and other spa water chemicals. To extend their life, whenever the spa shell is being cleaned, the spa pillows should be removed and cleaned. Body oils can be removed with a mild soap and water solution. ALWAYS rinse off the spa pillows thoroughly to remove any soap residue. If the spa is not going to be used for a long period of time (that is during a vacation or if the spa is winterized), or when the spa water is being super-chlorinated, the spa pillows should be removed until the next use of the spa.

To remove and replace the spa pillows:

1. Place your hand in the upper corner of the pillow, between the spa shell and pillow. Carefully pull the pillow away from the shell until the corner of the pillow unsnaps from the spa shell.
2. Repeat step 1 with the other upper corner of the pillow.
3. To replace, simply snap both of the upper corners into the spa shell.

CARE OF THE EXTERIOR

SPA SHELL

Your Caldera™ Spa has a Quarite Select® shell. Stains and dirt generally will not adhere to your spa's surface. A soft rag or a nylon scrubber should easily remove most dirt. Most household chemicals are harmful to your spa's shell. The only products which have passed the manufacturer's tests are Soft Scrub® and Windex®. Sodium bicarbonate (baking soda) can also be used for minor surface cleaning. Always thoroughly rinse off any spa shell cleaning agent with fresh water.

SERVICE NOTES:

1. Iron and copper in the water can stain the spa shell if allowed to go unchecked. Your Caldera™ Dealer can recommend a Stain and Scale Inhibitor to use if your spa water has a high concentration of dissolved minerals.
2. The use of alcohol or any household cleaners other than those listed to clean the spa shell surface is NOT recommended. DO NOT use any cleaning products containing abrasives or solvents since they may damage the shell surface. **NEVER USE HARSH CHEMICALS!** Damage to the shell by the use of harsh chemicals is not covered under the warranty.

IMPORTANT: Some surface cleaners contain eye and skin irritants. Keep all cleaners out of the reach of children and use care when applying.

CARE OF THE SPA COVER

WARNING: The cover is a manual safety cover that meets or exceeds all prevailing requirements of ASTM Standards for spa safety covers when installed and used correctly as of the date of manufacture. Non-secured or improperly secured covers are a hazard. Open the cover to its fully open position before use.

VINYL COVER

The vinyl spa cover is an attractive, durable foam insulation product. Monthly cleaning and conditioning are recommended to maintain its beauty.

To clean and condition the vinyl cover:

1. Remove the cover from the spa and gently lean it against a wall or fence.
2. With a garden hose, spray the cover to loosen and rinse away dirt or debris.
3. Using a large sponge and/or a soft bristle brush, and using a very mild soap solution (1 teaspoon dishwashing liquid with 2 gallons of water) or baking soda (sodium bicarbonate), scrub the vinyl top in a circular motion. Do not let the vinyl dry with a soap film on it before it can be rinsed clean.
4. Scrub the cover's perimeter and side flaps. Rinse clean with water.
5. Rinse off the underside of the cover with water only (use no soap), and wipe it clean with a dry rag.

SERVICE NOTE: To remove tree sap, use cigarette lighter fluid (not charcoal lighter fluid). Use sparingly, and rinse with a saddle soap solution immediately afterwards, then wipe dry.

Important reminders:

- **DO** remove snow buildup to avoid breakage of the foam core from the additional weight of the snow.
- **DO** lock cover lock straps to secure the cover when the spa is not in use.
- **DO NOT** drag or lift the spa cover using either the flaps or the cover lock straps.
- **DO NOT** walk, stand, or sit on the cover.
- **DO NOT** place any metal or heat transferring object on the cover or place any type of plastic tarp or drop cloth over the cover as this may result in a melted foam core, which would not be covered under the warranty.
- **DO NOT** use any lifting mechanisms, chemicals or cleaners except those recommended by Watkins Manufacturing Corporation or its Authorized Sales and Service Dealer.

V. Water Quality And Maintenance

It's important to have clean water. Water maintenance is one of the least understood, yet most important areas of spa ownership. Your dealer can guide you through the process of achieving and maintaining perfect water in your spa, given your local conditions. Your program will depend on your water's mineral content, how often you use your spa, and how many people use it.

GENERAL INFORMATION

THE THREE FUNDAMENTAL AREAS OF WATER MAINTENANCE:

- **Water Filtration**
- **Chemical Balance/pH Control**
- **Water Sanitation**

Water Sanitation is the responsibility of the spa owner, achieved through the regular and periodic (daily, if necessary) addition of an approved sanitizer. The sanitizer will chemically control the bacteria and viruses present in the fill water or introduced during use of the spa. Bacteria and viruses can grow quickly in undersanitized spa water.

The water's chemical balance and pH control are also the responsibility of the spa owner. You'll have to add chemicals to maintain proper levels of Total Alkalinity (TA), Calcium Hardness (CH) and pH. Proper water balance and pH control will minimize scale buildup, extend the life of the spa, and allow the sanitizer to work at top efficiency.

METHODS FOR TESTING THE SPA WATER

Accurate water testing and analysis is an important part of effectively managing your spa water. You must have the ability to test for:

- Total Alkalinity (TA)
- Calcium Hardness (CH)
- pH
- Sanitizer

Two types of testing methods are recognized and recommended by Watkins:

The Reagent Test Kit is a method which provides a high level of accuracy. The reagents come in either liquid or tablet form.

Test Strips are a convenient testing method used by many spa owners. Keep in mind that test strips are susceptible to heat and moisture contamination, which will result in inaccurate readings.

IMPORTANT: Always read and carefully follow the directions included with the Test Kit or Test Strips to ensure the accuracy of the test results.

BASIC CHEMICAL SAFETY

When using chemicals, read the labels carefully and follow directions precisely. Though chemicals protect you and your spa when used correctly, they can be hazardous in concentrated form. Always observe the following guidelines:

- Allow only a responsible person to handle spa chemicals. Keep them out of the reach of children.
- Accurately measure the exact quantities specified, never more. Do not overdose your spa.
- Handle all containers with care. Store in a cool, dry, well ventilated place.
- Always keep chemical containers closed when not in use. Replace caps on their proper containers.
- Don't inhale fumes or allow chemicals to come in contact with your eyes, nose, or mouth. Wash your hands immediately after use.
- Follow the emergency advice on the product label in case of accidental contact, or if the chemical is swallowed. Call a doctor or the local Poison Control Center. If a doctor is needed, take the product container along so that the substance can be identified.
- Don't let chemicals get on surrounding surfaces or landscaping.
- Don't use a vacuum cleaner to clean up chemical spills.
- Never smoke around chemicals. Some fumes can be highly flammable.
- Don't store any chemicals in the spa equipment compartment.

HOW TO ADD CHEMICALS TO THE WATER

IMPORTANT: All spa water chemicals, including granulated dichlor, granulated pH increaser or decreaser, granulated total alkalinity increaser, calcium hardness increaser, liquid stain and scale inhibitor, and liquid de-foamer must always be added directly into the filter compartment while the jet pump is running, and it must run for a minimum of ten minutes.

To Administer Spa Water Chemicals:

1. Fold back the cover. Carefully remove and set aside the filter compartment cover (if applicable).
2. Push the Jets 1 and Jets 2 button (for the Kauai and Martinique, push the Jets button) to turn the jet pump on.
3. Carefully measure the recommended amount of chemical and slowly pour it into the filter compartment. Use care not to splash chemicals on your hands, in your eyes, on the spa shell surface or on the siding.

WATER QUALITY AND MAINTENANCE

4. Replace the filter compartment cover (if applicable). After ten minutes, shut off the jet pump(s) and close and lock the cover to complete the procedure. **Risk of Drowning:** Never leave an open spa unattended!

WARNING: High sanitizer levels can cause discomfort to the user's eyes, lungs and skin. Always allow the sanitizer level to fall to the recommended range before using the spa.

IMPORTANT "SUPER CHLORINATION/NON-CHLORINE SHOCK TREATMENT" NOTE: After administering a super chlorination treatment or non-chlorine shock to your spa, leave the cover open for a minimum of 20 minutes to allow the oxidizer gas to vent. A high concentration of trapped oxidizer gas which may exist as a result of the shock treatment (not daily sanitation) may eventually cause discoloration or vinyl degradation to the bottom of the cover. This type of damage is considered chemical abuse and is not covered under the terms of the limited warranty.

THE CALDERA™ SPA WATER MAINTENANCE PROGRAM

Each step in your water maintenance program is dependent on the completion of the previous steps. Omitting a step or failing to reach the recommended range may cause an imbalance in your water's chemistry. Unbalanced water chemistry can damage the spa and its components as well as cause discomfort for the user.

BALANCING THE TOTAL ALKALINITY (TA)

- A. The recommended Total Alkalinity (TA) for your spa water is 125-150 ppm.
- B. Total Alkalinity is a measure of the total levels of carbonates, bicarbonates, hydroxides, and other alkaline substances in the water. TA is referred to as the water's "pH buffer". In other words, it's a measure of the ability of the water to resist changes in pH level.
- C. If the TA is too low, the pH level will fluctuate widely from high to low. Fluctuations in pH can cause corrosion or scaling of the spa components. **Low TA can be corrected by adding sodium bicarbonate.**
- D. If the Total Alkalinity is too high, the pH level will tend to be high and may be difficult to bring down. **It can be lowered by using sodium bisulfate.**
- E. Once the TA is balanced, it normally remains stable, although the addition of more water with a high or low alkalinity will raise or lower the TA reading of the water.
- F. When the Total Alkalinity is within the recommended range, proceed to the next step.

BALANCING THE CALCIUM HARDNESS (CH)

- A. The recommended Calcium Hardness (CH) level for your spa is 150-200 ppm.
- B. Calcium Hardness is a measure of the total amount of dissolved calcium in the water. Calcium helps control the corrosive nature of the spa's water. That's why calcium-low water (commonly known as "soft" water) is not recommended. It is very corrosive to the equipment, and can cause staining of the spa shell.
- C. If the CH is too high (commonly known as "hard water"), formation of scale on the spa's shell surface and equipment can result. **CH can be decreased by dilution—a mixture of 75% hard and 25% soft water will usually yield a reading within the correct range.** If soft water is not available or practical for you, a stain and scale control should be added to the spa water, according to instructions on its label.
- D. Once the CH is balanced, it normally remains stable, although the addition of more water with a high or low calcium content will raise or lower the CH reading of the water.
- E. When the Calcium Hardness is within the recommended range, proceed to the next step.

BALANCING THE PH

- A. The recommended pH level for your spa water is 7.4-7.6.
- B. The pH level is the measure of acidity and alkalinity. Values above 7 are alkaline; those below 7 are acidic. Maintaining the proper pH level is extremely important for:
 - Optimizing the effectiveness of the sanitizer.
 - Maintaining water that is comfortable for the user.
 - Preventing equipment deterioration.
- C. If the spa water's pH level is too low, the following may result:
 - The sanitizer will dissipate rapidly.
 - The water may become irritating to spa users.
 - The spa's equipment may corrode.

If the pH is too low, it can be increased by adding sodium hydrogen carbonate to the spa water.

- D. If the pH level is too high, the following may result:
 - The sanitizer is less effective.
 - Scale will form on the spa shell surface and the equipment.
 - The water may become cloudy.
 - The filter cartridge pores may become obstructed.

If the pH is too high, it can be decreased by adding sodium bisulfate to the spa water.

NOTE: After adding sodium carbonate or sodium bisulfate, **wait two hours** before testing the water for pH. Measurements taken too soon may not be accurate.

- E. It is important to check the pH on a regular (weekly) basis. The pH will be affected by the bather load, the addition of new water, the addition of various chemicals, and the type of sanitizer used.

ALKALINE TUB WATER (SCALING ZONE)	8.2	ADD pH DECREASER TO LOWER pH
	7.8	
	7.6	
COMFORT ZONE	7.4	IDEAL
ACIDIC TUB WATER (CORROSIVE ZONE)	7.2	ADD pH INCREASER TO RAISE pH
	6.8	
	pH	

WATER QUALITY AND MAINTENANCE

F. When the pH is within the recommended range, proceed to the final step.

MAINTAINING THE SANITIZER LEVEL

- A. Sanitizer is extremely important for killing algae, bacteria and viruses, and preventing unwanted organisms from growing in the spa. At the same time, you don't want too high a sanitizer level, or it can irritate your skin, lungs and eyes.
- B. Always maintain the sanitizer level in your spa at the recommended level for each type of sanitizer.
- C. Watkins recommends only the following sanitizers:
 - Sodium Dichloro-s-Triazinetrione (Sodium Dichlor or Chlorine)
 - Baqua Spa™ (please consult your Baqua Spa™ manual for instructions on the use of this product).
 - Brominating Concentrate™ (One Step Granular Bromine)

WARNING: DO NOT use tri-chlor chlorine, bromo-chloro-dimethyl-hydantoin (BCDMH), or any type of compressed bromine or chlorine, acid or any type of sanitizer which is not recommended by Watkins.

THE WATKINS WATER MAINTENANCE QUICK REFERENCE GUIDE				
Steps	Ideal Range (ppm)		What Chemicals to Use	
	Minimum	Maximum	To Raise	To Lower
1 Total Alkalinity	125	150	Sodium Hydrogen Carbonate, or Sodium Bicarbonate	Sodium Bisulfate
2 Calcium Hardness	150	200	Calcium Hardness Increaser	Use a mixture of 75% hard water and 25% soft water or use a Stain and Scale Inhibitor
3 pH	7.4	7.6	Sodium Hydrogen Carbonate	Sodium Bisulfate
4 Sanitizer	See section on Maintaining the Sanitizer Level			

CHLORINE (SODIUM DICHLOR)

- A. Sanitizing chemicals, such as chlorine, are oxidants that kill bacteria and viruses in the water. The Free Available Chlorine (FAC) is a measure of the amount of unused chlorine available to sanitize the spa. The recommended FAC for your spa water is 3.0-5.0 ppm.
- B. Watkins Manufacturing Corporation recommends the use of Sodium Dichlor type granulated chlorine for sanitizing the water. Sodium Dichlor is preferred because it is totally soluble, dissolves quickly and is nearly pH neutral.
- C. Maintaining the proper level of chlorine during use is extremely important.
- D. If the FAC is too low, bacteria and viruses can grow rapidly in the warm water. **Increase the FAC by adding granulated Sodium Dichlor.**
- E. If the FAC is too high, the water can cause discomfort to the user's eyes, lungs and skin. **Simply allow some time to pass. The FAC level will drop naturally over time.**
- F. When the Free Available Chlorine is within the recommended range, the spa is ready to be enjoyed.

WARNING: There are several forms of stabilized chlorine available for use in spas and swimming pools and each form has specific chemical characteristics. It is extremely important that the one you choose is specifically designed for use in spas. Use of an incorrect product such as tri-chlor, which has a very low pH (2.6), dissolves too quickly in hot water resulting in extremely high levels of chlorine, and is designed for concrete or plaster swimming pools, WILL cause damage to your spa. Use of a liquid or any type of compressed bromine or chlorine, acid or any type of sanitizer which is not recommended by Watkins Manufacturing Corporation WILL damage your spa and is specifically not covered under the terms of the limited warranty.

IMPORTANT: Granulated chlorine (Sodium Dichlor) will degrade if stored improperly. We recommend purchasing chlorine in one or two pound containers and storing it in a cool, dry place to maintain its potency.

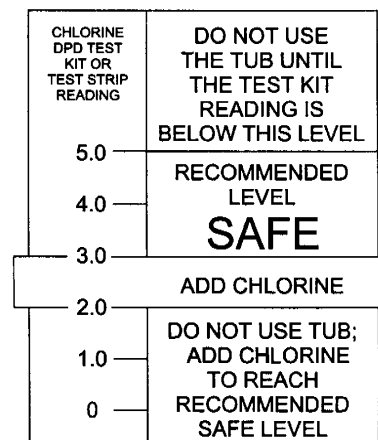

WATER QUALITY AND MAINTENANCE

SUPER CHLORINATION

Super Chlorination is designed to “burn-off” the build-up of chloramines (used chlorine), to eliminate the chlorine smell and to allow the proper level of free chlorine to be maintained.

When giving your water a super chlorination treatment, open the cover at least half way for twenty minutes to allow the chlorine gas to vent off. The high concentration of chlorine gas which may exist as a result of super chlorination (not daily sanitation) may eventually cause discoloration or degradation to the bottom of the cover or the tile grouting, which would not be covered under the terms of your warranty.

IMPORTANT: Always allow the Free Available Chlorine to fall to 5 ppm before using the spa.

WARNING: Never leave an open spa unattended, especially if there are children present!

BUILDING A SANITIZER ROUTINE

During the first month of ownership, measure the sanitizer residual daily in order to establish standards for User Load and Usage Time versus Sanitizer Needed.

- The User Load of the spa is the number of times anyone enters the spa.
- The Usage Time is simply the amount of time a user spends in the spa.
- Sanitizer Needed is the amount of Free Available Chlorine (FAC) needed to accommodate the number of users and their combined usage time.

For example, two spa users who regularly use the spa once an evening for twenty minutes create a specific and somewhat consistent demand on the sanitizer. During the first month of ownership, these two users can determine exactly how much sanitizer to use in order to maintain the proper residual. If, at any time, the user load and/or usage pattern changes dramatically (invited guests), the amount and frequency of sanitizer required increases dramatically.

The greater the usage time or the bather load, the faster the residual value is diminished.

CALDERA™ WATER TREATMENT GUIDE	
At spa startup or refill	Follow spa Start-Up and Refill Procedures.
Prior to each use (Test before adding any chemicals; do not add any chemicals if proper or higher levels are found.)	Add one-half (1/2) teaspoon of sodium dichlor per 250 gallons.
Once a week	Add one and one half (1-1/2) teaspoons of sodium dichlor per 250 gallons.
Every four months	Drain and refill your spa. Follow spa Start-Up and Refill Procedures.
As needed (if water is hazy, cloudy or has an odor)	Add one and one half (1-1/2) teaspoons of sodium dichlor per 250 gallons.

SUPPLEMENTAL WATER MAINTENANCE

Proper water sanitation and mineral balance (pH control) are absolutely essential for a complete spa water maintenance program. Here are three other popular water additives that are optional:

Mineral Deposit Inhibitors

As water evaporates from your spa and new water is added, the amount of dissolved minerals will increase. (Minimize evaporation by keeping the cover on the spa whenever possible.) The spa water may eventually become “hard” (Calcium Hardness too high) enough to damage the heater by calcifying its surface. Proper pH control can minimize this.

Normal soap build-up will require water replacement regularly enough that mineral deposits normally are not a problem.

Occasionally, high iron or copper content in the water may produce green or brown stains on the spa. A mineral deposit inhibitor may help to reduce these metals.

NOTE: Well water may contain high concentrations of minerals. The use of a low water volume, extra-fine pore water filter will help to remove many of the larger particles during the filling of the spa.

Foam Inhibitors

Spa water requires changing due to the buildup of soap in the water. Typically, soap will cause the spa water to foam when the jets are used. Soap is introduced into the spa water from two sources: users’ bodies, which retain a soap residue after showering, and swimming apparel, which retains soap after washing.

WATER QUALITY AND MAINTENANCE

Foam inhibitors can suppress foam, but cannot remove soap from the water. Soap is very difficult to remove from the water because soap is not oxidized by any chemical added to the spa. Only ozone can oxidize soap.

Eventually the soap build-up in the water will be concentrated, resulting in an unclean feeling on the bather's skin which is impossible to remedy. When this occurs, it's time to drain and refill the spa. Depending on the soap input, the water should last about 4 months before needing to be drained.

OZONE (Optional)

The Caldera™ high output ozone system is the only ozone purification system approved for installation in your Caldera™ Spa. The Caldera™ ozone system utilizes corona discharge (CD) technology to produce a higher concentration of ozone than is produced by competing ultraviolet light (UV) ozone systems.

The under-the-skirt mounted Caldera™ high output ozone system unit offers less-visible installation and is less susceptible to the effects of freezing temperatures. To access it for inspection, remove the equipment compartment door to check the unit operation (this is usually done prior to disconnecting the power to the spa before draining). Simply listen for the buzz of the transformer to verify operation of the Caldera™ high output ozone system.

The Caldera™ high output ozone system greatly enhances the quality of the spa water when used to supplement the spa owner's regular water maintenance program. Contrary to some information circulated throughout the pool and spa industry regarding ozone systems, ozone CAN NOT be used as a single-source sanitizer, water clarifier, anti-foamer, and mineral chelating agent. Watkins Manufacturing Corporation recommends that a chemical maintenance program based on recognized and documented industry standards still be followed when using an ozone purification system to assure water sanitation and the highest quality purified water.

Cleaning the Ozone Injector

On occasion, a mineral build-up may clog the ozone injector causing a lack of flow or low flow of ozone bubbles. To prevent this, refer to the following instructions to clean the injector:

1. Disconnect power to the spa.
2. Access the equipment compartment.
3. Locate the Ozonator in the equipment compartment and unplug the Ozonator from the control box.



Nitric acid accumulates in the air lines of the ozonator and injector. Nitric acid will cause severe chemical burns if direct skin contact is made, so always wear protective gloves, glasses and clothing when working on the ozonator or injector lines. To prevent inhalation or ingestion of the nitric acid, DO NOT blow or inhale with your mouth to any of the adapters, fittings or tubing of the ozonator or injector air lines.

4. Place 16 ounces of white vinegar into a container such as a cup or bucket. Place the container on the equipment compartment floor. NOTE: White vinegar will not damage any of the spa components.
5. Carefully loosen the long noreprene® tubing to the bottom of the ozonator. **A liquid substance may be found inside the tubing. If a liquid substance is present, BE CERTAIN NOT TO COME INTO CONTACT WITH THE LIQUID (SEE WARNING ABOVE).**
6. Place the end of the tubing into the vinegar, making certain that the end of the tubing sits at the bottom of the container.
7. Reconnect power to the spa.
8. Run the spa until all 16 ounces of the vinegar are gone. This should allow an ample flow of vinegar to be run through the injector and clear the blockage.
9. Disconnect power to the spa.
10. Remove the empty cup or bucket.
11. Reinstall the tubing to the bottom of the ozonator.
12. Plug the Ozonator into the control box.
13. Close the equipment compartment door.
14. Reconnect power to the spa.

WATER QUALITY AND MAINTENANCE

DOS AND DON'TS

- DON'T use swimming pool (muriatic) acid to lower pH.
- DON'T splash pH increaser additives on the siding.
- DON'T use Compressed Sanitizers.

The use of bromine sticks or tablets in floaters, which may become entrapped in a lounge or cooling seat (or sink to the spa floor), have been shown to cause discoloration of or surface distress to a spa's shell.

- DON'T use a floater type sanitization system as a low or no maintenance solution to your spa maintenance program.

The spa shell can easily withstand the effects of a properly administered sanitizer. Floating dispensers can become trapped in one area and cause an over-sanitization (or chemical burn) of that particular area.

If the dispenser setting is too high, the high concentration can discolor the spa shell and damage the underside of the cover.

Automatic floating dispensers have a tendency to either over-brominate or under-brominate as the rate of erosion varies greatly. Damage to the spa and cover can occur very quickly.

WARNING: Watkins Manufacturing Corporation DOES NOT recommend the use of any floating chemical dispenser. Damage to the spa shell or components caused by a floating chemical dispenser is specifically not covered under the terms of the limited warranty.

- DON'T use a sanitizer which is not designed for spas.
- DON'T use Household Bleach (liquid sodium hypochlorite).
- DON'T broadcast or sprinkle the chemicals onto the water surface. This method may cause chemically-induced spa surface blistering (chemical abuse).
- DO add all chemicals slowly into the filter compartment with the jet pump operating for ten minutes.
- DO use special care if using baking soda to clean either the interior or exterior plastic surfaces.
- DO use only a granular form of sanitizer (chlorine).

COMMON WATER CHEMISTRY QUESTIONS

Question: Why can't I use a floater to sanitize my spa water?

Answer: Watkins does not recommend the use of a floater for three reasons.

1. The floater is unable to control the rate at which sanitizer is dissolved into the water. When a floater is first placed in a spa, the sanitizer level can be extremely high. High sanitizer levels can chemically burn or discolor the spa's shell or the underside of the cover. Then, after a period of time, the sanitizer level dispensed by the floater will fall to near zero. A low sanitizer level will allow viruses, bacteria or algae to grow.
2. Floaters tend to stay in one area of the spa most of the time (usually over the cool down seat), causing this area to be exposed to extreme sanitizer levels.
3. The floater may allow pieces of the highly concentrated sanitizer to fall out and settle on the floor or seat of the spa shell. These pieces of sanitizer will chemically burn (blister) the spa shell. Although your spa shell is specifically designed to resist the effects of spa chemicals, no spa surface can withstand this type of highly concentrated chemical. Remember, chemical abuse is specifically not covered under the terms of the warranty.

Question: When I open my spa, I smell chlorine. How do I get rid of this smell?

Answer: There are two types of chlorine in your spa. The first is the Free Available Chlorine, which is the chlorine available to sanitize your spa. This available free chlorine does not have an odor. The second is Chloramine, which is residue from chlorine already expended. Chloramines have a strong chlorine odor. The smell from Chloramines can be eliminated by "shocking" the water. If you smell chlorine in the water, your spa is reminding you to add a shock treatment.

Question: Why can't I fill my spa with soft water?

Answer: Soft water is essentially the same as regular water except that most or all of the calcium has been replaced by sodium. Soft water may be corrosive to the heater and other components. Replacement of spa components damaged by soft water is extremely expensive.

Question: I am trying to reduce the number of chemicals to which my family is exposed. Do I really need to use so many chemicals and in such large amounts?

Answer: While over-exposure to any chemical can be unhealthful, many low levels of chemicals are effective and beneficial. In the case of spa water, the chemicals recommended in the Caldera™ Spa Water Maintenance program are needed to protect the user from water-borne pathogens (disease-causing microbes) and to prevent corrosion of spa components.

Question: Why isn't water chemistry damage covered by the warranty?

Answer: The chemical levels and water quality of the water in the spa are under your direct control. With proper basic care, the spa will provide many years of hot water relaxation. If you are unsure about any chemical or its usage in the spa, contact your Authorized Caldera Dealer or Watkins Manufacturing.

WATER TERMINOLOGY

The following chemical terms are used in this Water Quality and Maintenance section. Understanding their meaning will help you to better understand the water maintenance process.

Bromamines: Compounds formed when bromine combines with nitrogen from body oils, urine, perspiration, etc. Unlike chloramines, bromamines have no pungent odor and are effective sanitizers.

Bromine: A halogen sanitizer (in the same chemical family as chlorine). Bromine is commonly used in stick, tablet, or granular form. See the DO's and DON'Ts of Spa Water Maintenance for additional information.

Calcium Hardness: The amount of dissolved calcium in the spa water. This should be approximately 150-200 ppm. High levels of calcium can cause cloudy water and scaling. Low levels can cause harm to the spa equipment.

WATER QUALITY AND MAINTENANCE

Chloramines: Compounds formed when chlorine combines with nitrogen from body oils, urine, perspiration, etc. Chloramines can cause eye irritation as well as having a strong odor. Unlike bromamines, chloramines are weaker, slower sanitizers.

Chlorine: An efficient sanitizing chemical for spas. Watkins Manufacturing Corporation recommends the use of Sodium Dichlor-type granulated chlorine. This type is preferred because it is totally soluble and nearly pH neutral.

Chlorine (or Bromine) Residual: The amount of chlorine or bromine remaining after chlorine or bromine demand has been satisfied. The residual is, therefore, the amount of sanitizer which is chemically available to kill bacteria, viruses and algae.

Corrosion: The gradual wearing away of metal spa parts, usually caused by chemical action. Generally, corrosion is caused by low pH or by water with levels of TA, CH, pH or sanitizer which are outside the recommended ranges.

DPD: The preferred reagent used in test kits to measure the Free Available Chlorine.

Halogen: Any one of these five elements: fluorine, chlorine, bromine, iodine and astatine.

MPS: Monopersulfate is the non-chlorine oxidizer.

Oxidizer: The use of an oxidizing chemical is to prevent the buildup of contaminants, maximize sanitizer efficiency, minimize combined chlorine and improve water clarity.

Pathogen: A microorganism such as bacterium that cause disease.

pH: The measure of the spa water's acidity and alkalinity. The recommended pH for the spa water is 7.4 to 7.6. Below 7.0 (considered neutral), the spa water is too acidic and can damage the heating system. Above 7.8, the water is too alkaline and can result in cloudy water and scale formation on the shell and heater.

ppm: The abbreviation of "parts per million", the standard measurement of chemical concentration in water. Identical to mg/l (milligrams per liter).

Reagent: A chemical material in liquid, powder or tablet form for use in chemical testing.

Sanitizer: Sanitizers are added and maintained at recommended residuals to protect bathers against pathogenic organisms which can cause disease and infection in spa water.

Scale: Rough calcium-bearing deposits that can coat spa surfaces, heaters, plumbing lines and clog filters. Generally, scaling is caused by mineral content combined with high pH. Additionally, scale forms more readily at higher water temperatures.

Shock Treatment: Also known as "super-chlorination" when chlorine is used. Shock treatment is a process of adding significant doses of a quick dissolving sanitizer (sodium dichlor is recommended) to oxidize non-filterable organic waste and to remove chloramines and bromamines.

Total Alkalinity: The amount of bicarbonates, carbonates, and hydroxides present in spa water. Proper total alkalinity is important for pH control. If the TA is too high, the pH is difficult to adjust. If the TA is too low, the pH will be difficult to hold at the proper level. The desired range of TA in spa water is 125 to 150 ppm.

CALDERA™ OZONE SYSTEM (Optional)

The Caldera™ ozone system is practically maintenance-free because it is located within the spa's equipment compartment. If bubbles are appearing at the spa's heater return but the smell of ozone is not noticeable (the water may also appear not as clear as usual) then the operation of the ozone generator should be checked. Carefully open the equipment compartment door (remember to use care, as power is still connected to the spa) and verify that the CD tube and its transformer are energized (a slight buzz will be emitted from the ozone generator housing). If a slight buzz or hum is not audible, verify that the generator is completely plugged into the spa's control box.

If the unit is plugged in and power is connected to the spa, then the fuse (for the ozone generator) should be checked.

WARNING: Contact your Caldera™ Spa Dealer if your spa requires troubleshooting beyond the scope of this manual. Caldera™ ozone systems should only be serviced by a qualified technician.

WARRANTY NOTE: Cleaning of the ozone injector is not covered under the warranty. Refer to the Ozone section of this manual for ozone injector cleaning instructions.

WATER QUALITY AND MAINTENANCE

SPA WATER MAINTENANCE TROUBLESHOOTING GUIDE

Problem	Probable causes	Solutions
Cloudy Water	<ul style="list-style-type: none"> • Dirty filters • Excessive oils / organic matter • Improper sanitization • Suspended particles / organic matter • Overused or old water 	<ul style="list-style-type: none"> • Clean filters • Shock spa with sanitizer • Add sanitizer • Adjust pH and/or alkalinity to recommended range • Run jet pump(s) and clean filters • Drain and refill the spa
Water Odor	<ul style="list-style-type: none"> • Excessive organics in water • Improper sanitization • Low pH 	<ul style="list-style-type: none"> • Shock spa with sanitizer • Add sanitizer • Adjust pH to recommended range
Chlorine Odor	<ul style="list-style-type: none"> • Chloramine level too high • Low pH 	<ul style="list-style-type: none"> • Shock spa with sanitizer • Adjust pH to recommended range
Musty Odor	<ul style="list-style-type: none"> • Bacteria or algae growth 	<ul style="list-style-type: none"> • Shock spa with sanitizer – if problem is visible or persistent, drain, clean and refill the spa
Organic buildup / scum ring around spa	<ul style="list-style-type: none"> • Buildup of oils and dirt 	<ul style="list-style-type: none"> • Wipe off scum with clean rag – if severe, drain the spa, use a spa surface and tile cleaner to remove the scum and refill the spa
Algae Growth	<ul style="list-style-type: none"> • High pH • Low sanitizer level 	<ul style="list-style-type: none"> • Shock spa with sanitizer and adjust pH • Shock spa with sanitizer and maintain sanitizer level
Eye Irritation	<ul style="list-style-type: none"> • Low pH • Low sanitizer level 	<ul style="list-style-type: none"> • Adjust pH • Shock spa with sanitizer and maintain sanitizer level
Skin Irritation / Rash	<ul style="list-style-type: none"> • Unsanitary water • Free chlorine level above 5 ppm 	<ul style="list-style-type: none"> • Shock spa with sanitizer and maintain sanitizer level • Allow free chlorine level to drop below 5 ppm before spa use
Stains	<ul style="list-style-type: none"> • Total alkalinity and/or pH too low • High iron or copper in source water 	<ul style="list-style-type: none"> • Adjust total alkalinity and/or pH • Use a metal deposit inhibitor
Scale	<ul style="list-style-type: none"> • High calcium content in water – total alkalinity and pH too high 	<ul style="list-style-type: none"> • Adjust total alkalinity and pH – if scale requires removal, drain the spa, scrub off the scale, refill the spa and balance the water

MISCELLANEOUS SERVICE INFORMATION

The control and high limit thermostats are equipped with electronic sensors that are connected to the spa's plumbing. Never cut or kink the wires that connect the sensors to the thermostats within the control box.

The jet pump is equipped with a thermal overload cutoff switch that is designed to protect the pump from overheating. If the pump shuts itself off in an older spa, it could indicate failure of the pump motor bearings. If the pump shuts itself off in a new spa, it is usually the result of one or a combination of the following factors:

- **Thermal Overload:** Although mass-produced, not all thermal overload cutoffs are exactly the same. Some are more sensitive than others and will shut the pump off at lower temperatures.
- **High Temperature:** All Caldera™ Spa models are equipped with a jet pump shroud that vents the heat generated by the pump motor to the outside of the equipment compartment. If the vent is blocked by masonry, grass or debris, overheating of the jet pump may occur. Once the pump motor has cooled sufficiently and any blockage has been removed from the vent opening, the jet pump can be restarted.
- **Friction:** Sometimes the moving parts of a new pump are tight enough to cause heat buildup due to friction. After a normal break-in period, the pump will run cooler.
- **Improper Wiring:** If the spa is connected with an extension cord, and/or the house wiring is undersized, the pump may starve for voltage and therefore may draw more amperage and generate excessive heat.
- If the pump is shutting down due to excessive heat, make sure the equipment compartment has adequate ventilation. The air gap at the bottom must not be blocked. Should your jet pump continue to shut off after short periods of use, contact a qualified service technician.

ACTS INVALIDATING WARRANTY

The limited warranty is void if the Caldera™ Spa has been improperly installed, subjected to alteration, misuse or abuse, or if any repairs on the spa are attempted by anyone other than an authorized representative of Watkins Manufacturing Corporation. Alteration shall include any component or plumbing change, electrical conversion, or the addition of any non-approved sanitation or water purification device or heating system which contributes to component or unit failure or unsafe operating system. Misuse and abuse shall include any operation of the spa other than in accordance with Watkins Manufacturing Corporation printed instructions, or use of the spa in an application for which it is not designed; specifically: use of the spa in a non-residential application; damage caused by operation* of the spa at water temperatures outside the range of 35°F and 120 °F; damage caused by a dirty, clogged or calcified filter cartridge; damage to the spa surface caused by the use of Tri-Chloro Chlorine, BCDMH, chemical tablets in a floater, acid, or any other spa chemicals or spa surface cleaners which are not recommended by Watkins Manufacturing Corporation; damage caused by allowing undissolved spa sanitizing chemicals to lie on the spa surface (no spa surface material can withstand this kind of abuse); damage to components or spa surface caused by improper water chemistry maintenance; and damage to the spa surface caused by leaving the spa uncovered while empty of water and in direct exposure to sunlight (this may cause solar heating distress in warm weather regions). These are considered abuses and may invalidate this warranty.

*Operation of the spa does not mean "use" of the spa! Watkins Manufacturing Corporation does not recommend using the spa if the water temperature is above or below the spa's control panel temperature range.

DISCLAIMERS

Watkins Manufacturing Corporation shall not be liable for loss of use of the Caldera™ Spa or other incidental, consequential, special, indirect, or punitive costs, expenses or damages, which may include but are not limited to the removal of a permanent deck or other custom fixture or the necessity for crane removal. Any implied warranty shall have a duration equal to the duration of the applicable limited warranty stated above. Some states do not allow limitations on how long an implied warranty lasts. Under no circumstances shall Watkins Manufacturing Corporation or any of its representatives be held liable for injury to any person or damage to any property, however arising.

Some states do not allow the exclusion or limitation of incidental or consequential damages, so the above limitations may not apply to you.

WATKINS CUSTOMER SERVICE

If you have any questions about any aspect of your Caldera™ Spa set-up, operation or maintenance that have not been answered by this manual, consult your Caldera™ Spa Dealer.

Watkins Manufacturing Corporation can be reached at: 800-669-1881 (Extension 432), Monday through Friday, 8 am to 5 pm Pacific Standard Time (PST), or e-mail custserv@watkinsmfg.com.

SPA TROUBLESHOOTING

If your spa doesn't seem to be working the way you believe it should, please review the "start-up" and "operation" instructions in this manual. If this doesn't help you correct the problem, follow the appropriate instructions below. If the problem still is not resolved, call your Caldera dealer.

SYMPTOM	PROBABLE CAUSE	SOLUTIONS
Nothing works, Blank LCD screen	<ul style="list-style-type: none"> • Circuit breaker tripped or OFF. 	<ul style="list-style-type: none"> • Reset circuit breaker. • Reset GFCI.
Pump motor will not function	<ul style="list-style-type: none"> • Motor overload condition. • Control switch failure. 	<ul style="list-style-type: none"> • Let cool for 1 hour. Motor overload will reset automatically. If problem persists, contact your Caldera dealer. • Disconnect spa and contact your Caldera dealer.
Noisy pump or Motor	<ul style="list-style-type: none"> • Low water level. 	<ul style="list-style-type: none"> • Add water to normal level (1 inch above highest jet).
Pump motor runs, but low or no water/jet pressure	<ul style="list-style-type: none"> • Air control valve closed or blocked. • Low water level. • Dirty filter cartridge. • Jet blocked. • Clogged suction or skimmer basket. 	<ul style="list-style-type: none"> • Open or clean air valve. • Add water to normal level (1 inch above highest jet). • Clean filter cartridge. • Remove jet face eyeball and clean orifice. • Clean suction cover or skimmer basket.
<p>Priming the pump</p> <p>Upon filling or refilling the spa, if a pump is operating and water is not flowing from any of its jets, the pump may not be properly primed. To correct, refer to the Overhead View and perform the following procedures:</p> <ul style="list-style-type: none"> • Turn off power to the spa at the breaker and remove the equipment compartment door. • Loosen the union on the top of the pump to allow the air to escape. When water is present, hand-tighten the union. • Turn power back on, activate the pump and check to make sure union is tight enough to keep it from leaking. 		
Spa not heating properly	<ul style="list-style-type: none"> • Temperature set too low. • Spa cover improperly positioned. • Filter cycles too short in Economy mode. • Dirty filter cartridge. 	<ul style="list-style-type: none"> • Set control panel to a higher temperature. • Align spa cover. • Switch to standard mode and/or lengthen filter cycles. • Clean filter cartridge.
Diverter Valves are difficult to turn	<ul style="list-style-type: none"> • Sand or grit inside valve. 	<ul style="list-style-type: none"> • Clean and lubricate valve per Diverter Valve Maintenance instructions.

LCD MESSAGES

OH **Overheat Protection (spa is deactivated)** - If a malfunction occurs and spa water temperature reaches 112°F, the system will completely shut down. In such a condition, **DO NOT ENTER THE WATER.** Turn off all power to the spa and contact your Caldera dealer.

ICE **Freeze Protection** - If a potential freeze condition is detected, both jet pumps are automatically activated. This is a normal spa function; no corrective action is necessary. Freeze protection is enabled regardless of the spa's operating status.

FLO **Pressure switch (constantly displayed)** - An air lock may have occurred or a pressure switch has malfunctioned. Contact your Caldera dealer.

Pressure Switch (flashing) - The pressure switch is not detecting an adequate amount of water flow. Make sure the spa is filled to 1 inch above the highest jet. The spa will continue to operate, but the heater will not activate. Contact your Caldera dealer.

COOL **Temperature Set Back** - If the spa water temperature is more than 20°F cooler than the temperature set point, the heater will automatically activate to provide freeze protection. This is a normal spa function; no corrective action is necessary.

Sn1 **Open Sensor (spa is deactivated)** - The high limit temperature sensor is non-functional. This must be repaired only by your Caldera dealer or a qualified service organization.

Sn3 **Open Sensor (spa is deactivated)** - The water sensor is non-functional. This must be repaired only by your Caldera dealer or a qualified service organization.

PARADISE SERIES SPA SPECIFICATIONS

	Footprint dimensions	Height	Effective filter area	Heater (Watts)	Water capacity	Dry weight	Filled weight*	Dead weight*	Electrical Requirements
Geneva	7'5" x 7'5"	38"	100 Square feet	4,300	475 Gallons	920 Lbs.	5,915 Lbs.	115 Lbs. per square foot	230 volt, 50 amp Single phase GFCI protected circuit
Niagara	7'5" x 7'5"	38"	100 Square feet	4,300	500 Gallons	920 Lbs.	6,300 Lbs.	115 Lbs. per square foot	230 volt, 50 amp Single phase GFCI protected circuit
Tahitian	7'0" x 7'0"	36"	100 Square feet	4,300	360 Gallons	790 Lbs.	4,825 Lbs.	105 Lbs. per square foot	230 volt, 50 amp Single phase GFCI protected circuit
Hawaiian	7'0" x 7'0"	36"	100 Square feet	4,300	380 Gallons	800 Lbs.	5,180 Lbs.	105 Lbs. per square foot	230 volt, 50 amp Single phase GFCI protected circuit
Martinique	7'5" x 6'4"	34"	75 Square feet	4,300	320 Gallons	710 Lbs.	4,420 Lbs.	100 Lbs. per square foot	230 volt, 50 amp Single phase GFCI protected circuit
Kauai	7'0" x 5'5"	29"	75 Square feet	4,300	200 Gallons	610 Lbs.	2,795 Lbs.	95 Lbs. per square foot	230 volt, 50 amp Single phase GFCI protected circuit

CAUTION: Watkins Manufacturing Corporation suggests a structural engineer or contractor be consulted before the spa is placed on an elevated deck.

* **NOTE:** The "Filled weight" and "Dead weight" of the spa includes the weight of the occupants (assuming an average occupant weight of 175 lbs).

This manual contains installation, operating, maintenance and service information for the following Caldera™ Spa models:

MODELS	EFFECTIVE DATE
GENEVA	12/00
NIAGARA	12/00
TAHITIAN	12/00
HAWAIIAN	12/00
MARTINIQUE	12/00
KAUAI	12/00



©2000 Watkins Manufacturing Corporation. Caldera Spas, Pure Comfort, and The Home Relaxation Specialists are trademarks of Watkins Manufacturing Corporation. Quarite Select is a trademark of Aristech Acrylics LLC. Baqua Spa is a trademark of AVECIA, Inc. Windex® is a trademark of S.C. Johnson & Son, Inc. Soft Scrub® is a trademark of The Clorox Company.

Watkins
The Home Relaxation Specialists

Watkins Manufacturing Corporation
Vista, California
USA

PART #39274, REV. A (12/00)