

EMERALD SPA
CORPORATION

Owner's Manual



● Introduction

Congratulations on your purchase of the finest whirlpool spa on the market today. Emerald Spa Corporation welcomes you to the *Emerald Whirlpool Spa* Life-style! We are confident that this purchase will fulfill all your comfort, therapy and relaxation needs.

With proper care, your spa will provide many years of comfort and pleasure. Please take the time to read all of the instructions before you install your Emerald or Cygnus Series Spa. This Owner's Manual will help you understand all the features of your spa and ensure that you get the most from your investment.

Remember, your beautiful new spa is a powerful appliance! You owe it to yourself, your family and friends, to make sure that the spa is installed correctly and safely.

This manual explains safety precautions, installation instructions, operating directions, and maintenance procedures. If you have questions after reading this manual, please call your Emerald Spa Service Representative at 1-800-766-7727.

Read and understand all safety, installation, operating instructions and all warnings and cautions before adding water or attaching electrical power.

Information on Your Spa

Spa Model: _____

Power Pack Model: _____

Serial #: _____

- **Warnings, Cautions, and Notes**

Throughout this manual, various Warnings, Cautions, and Notes will appear in the left margin or at the beginning of the text associated with the Warning, Caution, or Note. These comments range in importance from helpful hints to situations where the possibility of personal injury exists. Please take the time to read and understand them. The pictures and drawings may not reflect product changes that occurred after the printing of this manual.

Warnings, Cautions, and Notes appear as follows:



WARNING:
Indicates a situation in which personal injury may occur.



CAUTION:
Indicates a situation in which damage to equipment or material may occur.

NOTE:
Provides helpful information for proper operation of your Emerald whirlpool spa.

- **Model and Serial Number Locations**

Refer to the illustration below to locate and record the model number and serial number of both your Spa and Spa Power Pack.

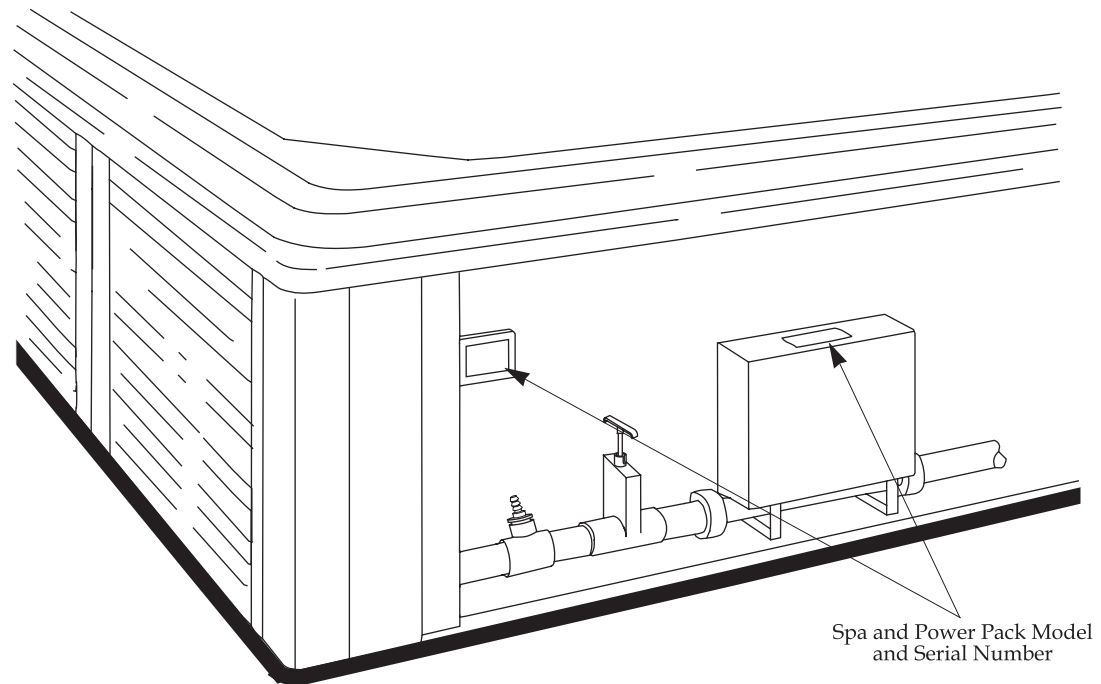

SAVE THESE INSTRUCTIONS

● Table of Contents

INTRODUCTION	2
IMPORTANT SAFETY INSTRUCTIONS	4-5
IMPORTANT USER SAFETY INSTRUCTIONS	6-7
SPA LOCATION	8
INSTALLATION INSTRUCTIONS	9
General Procedures	9
240V Systems.....	10-12
FEATURES AND CONTROLS.....	13
Spa At-A-Glance.....	13
Equipment Compartment.....	14
Power Pack.....	15-17
Spa Side Control Panels.....	18-30
Lite Leader.....	18-19
SS-1D.....	20-21
SS-3D.....	22-23
DS-2.....	24-26
DS-4.....	27-32
In Spa Features.....	33
Other Controls and Fixtures.....	34
STARTING AND USING YOUR SPA.....	35
Installation of Filter Element.....	35
Proper Water Level.....	36
Bleeding Air for one and two pump systems.....	36
Testing the Ground Fault Circuit Interrupter (GFCI).....	37
Pump Priming.....	37-38
Setting the Thermostat.....	39
SPA WATER CHEMISTRY.....	40
Chemical Safety Tips.....	40
Spa Capacity.....	40
pH Control.....	41
Disinfecting Your Spa.....	42
Ozone Generator.....	43
Other Water Chemistry Considerations.....	43
MAINTAINING YOUR SPA.....	44
Draining the Water.....	44
Cleaning the Spa Shell.....	45
Cleaning the Filter.....	45
Space Saver II Filtration System.....	46
Relamping the Underwater Light.....	46
Standby Mode.....	46
Winterizing Your Spa.....	47
The Spa Cabinet.....	47
TROUBLESHOOTING.....	48-52
Lite Leader, SS-1D & SS-3D.....	48-49
DS-2 & DS-4.....	50-52
ELECTRICAL SCHEMATICS	53-57
Lite Leader.....	53
SS-1D.....	54
SS-3D.....	55
DS-2.....	56
DS-4.....	57

General

IMPORTANT SAFETY INSTRUCTIONS

When installing and using this electrical equipment, basic safety precautions should always be adhered to, including the following:

1. **READ AND FOLLOW ALL INSTRUCTIONS.**
2. **WARNING:** To Reduce the risk of injury, do not permit children to use this product unless they are closely supervised at all times.
3. A wire connector is provided on this unit to connect a minimum No. 8 AWG (8.4mm²) solid copper conductor between this unit and any metal equipment, metal enclosures of electrical equipment, metal siding, metal sliding doors, metal rails, metal water pipe, or conduit within 5 feet (1.5m) of the unit.
4. **DANGER:** Risk of accidental drowning. Extreme caution must be exercised to prevent unauthorized access by children. To avoid accidents, ensure that children cannot use this spa unless they are supervised at all times.
5. **DANGER:** Risk of injury. The suction fittings in this spa are sized to match the specific water flow created by the pump. Should the need arise to replace the suction fittings or the pump, be sure that the flow rates are compatible. Never operate your spa if the suction fittings are broken or missing. Never replace a suction fitting with one rated less than the flow rate marked on the original suction fitting.
6. **DANGER:** Risk of electric shock. Install at least 5 feet (1.5m) from all metal surfaces. As an alternative, a spa may be installed within 5 feet of metal surfaces if each metal surface is permanently connected by a minimum No. 8 AWG (8.4mm²) solid copper conductor to the wire connector on the terminal box that is provided for this purpose.
7. **DANGER:** Risk of electric shock. Do not permit any electric appliance, such as a light, telephone, radio, or television within 5 feet (1.5m) of a spa.

SAVE THESE INSTRUCTIONS

*240V Hard Wired
Connected
Systems*

IMPORTANT SAFETY INSTRUCTIONS

When installing and using this electrical equipment, basic safety precautions should always be adhered to, including the following:

1. **READ AND FOLLOW ALL INSTRUCTIONS.**
2. Read and follow all General Safety Instructions provided on pg. 4.
3. A terminal marked "GROUND" is provided within the motor control enclosure. To reduce the risk of electrical shock, connect this terminal to the grounding terminal of the electric supply panel with a continuous green insulated copper wire equivalent in size to the circuit conductors supplying this equipment.
4. This equipment must be provided with a ground fault circuit interrupter located in the power supply panel as installed by an electrician. Before each use of your spa, with the power turned on, push the test button. A red indicator should appear. Push the reset button, and the red indicator should disappear. **IF THE INTERRUPTER FAILS TO OPERATE IN THIS MANNER, THERE IS A GROUND CURRENT FLOWING, INDICATING THE POSSIBILITY OF AN ELECTRIC SHOCK.** Shut off the power to the spa until the source of the breakdown has been identified and corrected.
5. The electrical service panel should be equipped with a 50-amp GFCI overcurrent protective device.
6. The minimum supply conductor capacity is 50 Amp and should be sized as follows:
No. 6 AWG, or No. 8 AWG 75° C.
7. The electrical supply for the spa must include a suitably rated switch or circuit breaker to open all ungrounded supply conductors, to comply with section 422-20 of the National Electrical Code, ANSI/NFPA 70-1999. The disconnecting means must be readily accessible to the spa occupant but must not be within 5 feet of the spa.

SAVE THESE INSTRUCTIONS

To Reduce the Risk of Injury

IMPORTANT USER SAFETY INSTRUCTIONS

When using this spa, basic safety precautions should always be followed.



WARNING:

As a spa owner, you should always review these instructions with first time or occasional users of the spa. Remember, they may not be aware of the possible risks associated with spa water temperature.

1. **READ AND FOLLOW ALL INSTRUCTIONS.**
2. **WARNING: TO REDUCE THE RISK OF INJURY**, do not permit children to use this product unless they are closely supervised at all times.
3. **DANGER: RISK OF ACCIDENTAL DROWNING.** Extreme caution must be exercised to prevent unauthorized access by children. To avoid accidents, ensure that children cannot use the spa unless they are supervised at all times.
4. **WARNING: TO REDUCE THE RISK OF INJURY**, the water in a spa should never exceed 104° F [40° C]. Water temperatures between 100° F [38° C] and 104° F [40° C] are considered safe for a healthy adult for a 10 to 15 minute time period. Lower water temperatures are recommended for extended use [exceeding 10-15 minutes] and for young children.
5. Since excessive water temperatures have a high potential for causing fetal damage during the early months of pregnancy, pregnant or possibly pregnant women should limit spa water temperatures to 100° F [38° C].
6. Before entering a spa, the user should measure the water temperature with an accurate thermometer such as a medical thermometer, since the tolerance of temperature regulating devices vary.
7. The use of alcohol, drugs, or medication before or during spa use may lead to unconsciousness with the possibility of drowning.

SAVE THESE INSTRUCTIONS

IMPORTANT USER SAFETY INSTRUCTIONS (Continued)

8. Persons suffering from obesity or with a medical history of heart disease, low or high blood pressure, circulatory system problems, or diabetes should consult a physician before using a spa.
9. Persons using medication should consult a physician before using a spa, since some medications may induce drowsiness while other medications may affect heart rate, blood pressure and circulation.
10. Extended use of your spa in water temperatures between 100° F and 104° F may cause HYPERTHERMIA (elevated body temperature). Hyperthermia occurs when the internal temperature of the body reaches a level several degrees above the normal body temperature of 98.6° F. The symptoms include dizziness, fainting, drowsiness, lethargy, and an increase in the internal temperature of the body. The effects of hyperthermia include (1) unawareness of impending hazard, (2) failure to perceive heat, (3) failure to recognize the need to exit the spa, (4) physical inability to exit the spa, (5) fetal damage in pregnant women, and (6) unconsciousness, resulting in a danger of drowning.
11. **WARNING:** The use of alcohol, drugs, or medication can greatly increase the risk of fatal hyperthermia in spas.
12. During Winter months where the temperature is consistently below freezing, check your spa periodically to assure that it is operating correctly and that the power to the spa has not been interrupted as to assure that the water lines are not in danger of freezing.
13. Do not use your spa alone.
14. Make sure that the following emergency telephone numbers are listed at the nearest telephone: physician, hospital, ambulance, and police.
15. Have at least one person in the family learn CPR (cardio-pulmonary resuscitation). It could save a life!

SAVE THESE INSTRUCTIONS

SPA LOCATION

- **Outdoor Considerations**
- **Indoor Considerations**

There are many things to consider prior to locating your spa. The following lists cover some of the more common factors involved in choosing the ideal location.

● **Outdoor Considerations**

- ✓ Local fencing and enclosure codes.
- ✓ Local electrical and plumbing codes.
- ✓ The view from your house.
- ✓ Your ability to supervise the spa.
- ✓ Wind direction and exposure to sunlight.
- ✓ Location relative to trees (falling leaves and shade).
- ✓ Dressing and bathroom location.
- ✓ Storage area for maintenance equipment and chemicals (storing chemicals inside your spa cabinet will void the warranty).
- ✓ Landscaping and evening lighting.
- ✓ Spa must be placed on a flat, level surface.
- ✓ Water is heavy. If a spa is placed on flooring or decking, be sure the structure is strong enough to support the added weight.

● **Indoor Considerations**

- ✓ Walls, ceiling, flooring, and woodwork must be able to withstand high humidity.
- ✓ You may need cross-ventilation fans or oversized dehumidifiers (or both) to remove excess humidity.
- ✓ Spa chemicals in the air may corrode certain metals in your home.
- ✓ Floor drains are needed to carry off water splashed from the spa.
- ✓ Recessed spas must be positioned to permit servicing from above or below floor.
- ✓ Water is heavy. Be sure the flooring or decking is strong enough to support the added weight.
- ✓ Due to the many precautions that must be taken to avoid damage to the surrounding environment from humidity and water inherent with spa use, it is usually prudent to avoid a second story location that may be above finished living space.

INSTALLATION INSTRUCTIONS

- General Procedures
- 240V Systems

- General Procedures

This section covers the installation of your spa. All electrical steps must be performed by a licensed electrician. The spa must be connected to a proper power supply and meet all National Electrical Code (N.E.C.) and local code requirements. The connection must include the conductors necessary for operation and bonding, as required by N.E.C.

1. Remove the spa from its shipping container and retain all safety, operation, and warranty information.
2. Position the spa on a flat, level surface such as concrete, or a wood deck which provides adequate drainage.
3. Position the spa at least 5 feet from all metal surfaces unless each metal surface is permanently connected to a bonding wire, as indicated in step 4.
4. The spa may be installed within 5 feet of metal surfaces as follows:
 - Installation must be in accordance with Article 680-42 of the National Electrical Code, ANSI/NFPA 70-1999.
 - Each metal surface must be permanently connected to a bonding wire which is attached to a pressure wire connector provided for that purpose.
 - The pressure wire connector is located on the equipment system control enclosure.
 - The bonding wire must be at least No. 8 AWG (8.4 mm²) solid copper wire.
 - The bonding wire must be attached to the pressure wire connector and all metal equipment, metal enclosures of electrical equipment, metal water pipe, or conduit within 5 feet of the spa.

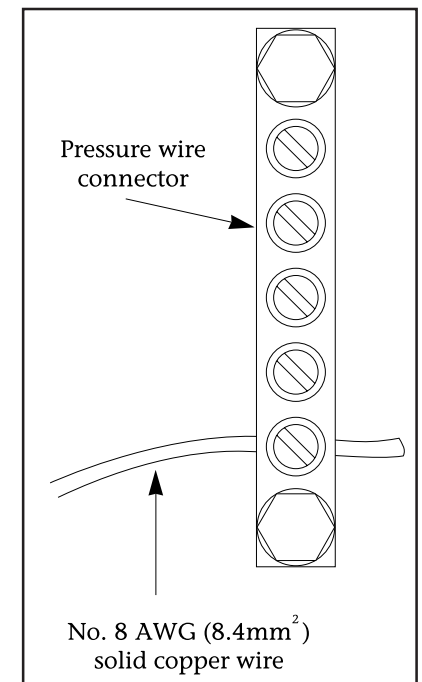

Located on the side of the spa pack box

- **240V Systems**
(Lite Leader 240V,
SS-1D, SS-3D,
DS-2, DS-4)

1. Install a 50-amp, GFCI overcurrent protective device in the electrical service panel.
2. The electrical supply for the spa must include a suitable rated switch or circuit breaker to shut off the power supply (to comply with section 422-20 of the National Electrical Code, ANSI/NFPA 70-1999). This disconnecting means must be readily accessible to the spa occupant, **but must not be within 5 feet of the spa.** (see diagram below)
3. With the spa placed in its final location, power can be routed in two ways:

Under the spa cabinet- See figure 1 on pg. 11

- Determine placement of hole in floor so that conduit may enter between the spa shell and the wooden cabinet.
- Move the spa to allow working room. Cut off the conduit above the floor surface.
- Use an LB on the conduit to permit wire pulling if required.

Through a power entrance opening drilled by an electrician - See figure 2 on pg. 11

- Move the spa to allow working room. Use nonmetallic conduit and fittings. Cut off the conduit above the floor surface to permit the installation of an LB at the power entrance opening height.

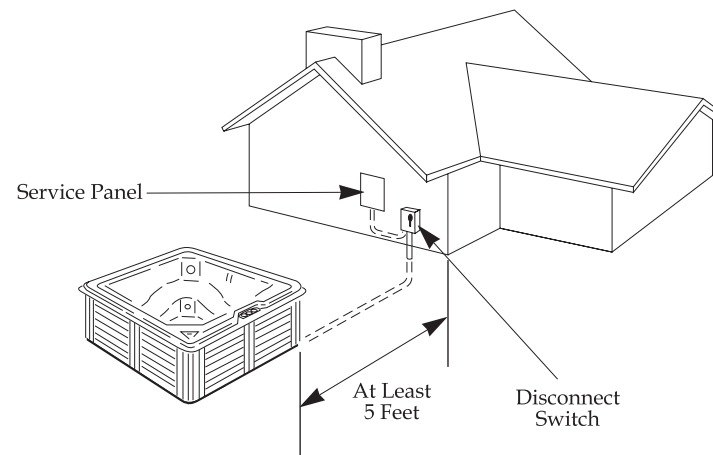

240V Systems [Continued]

4. Determine the length of flexible conduit required to run between the LB and control enclosure.
5. Pull 4 copper current carrying conductors (one each: black, red, white, green). Use either No. 6 AWG 60° C, No. 8 AWG 75° C, or No. 8 AWG 90° C wire, if spa is 100 feet or less away from its power supply. Note: the ground must be equal to or larger than the largest power conductor.
6. Reposition the spa at its final location and route the flexible conduit.
7. Using a 1" conduit connector at the end of the flexible conduit, route wires through an entrance hole cut by your electrician in the control enclosure, and attach the conduit connector to the control enclosure.

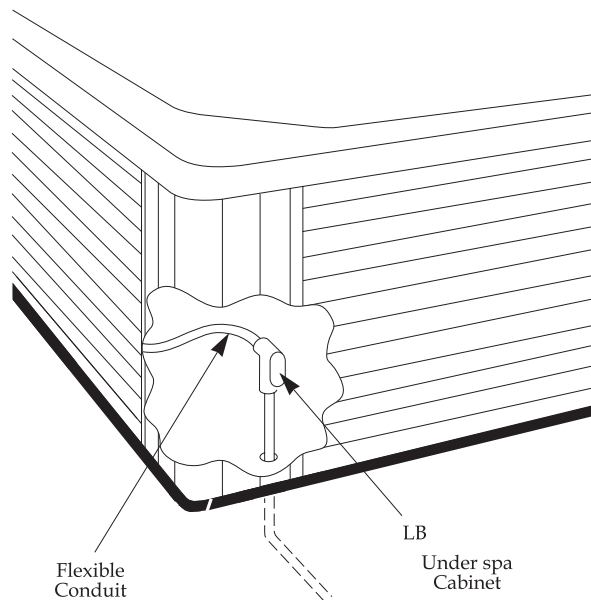

Figure 1

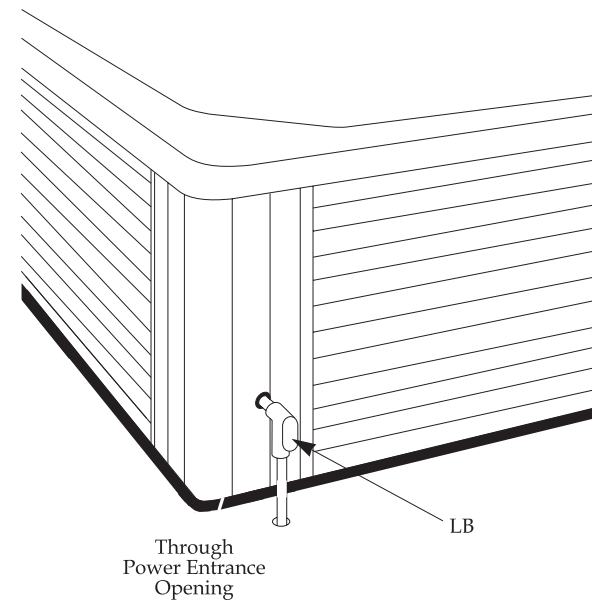
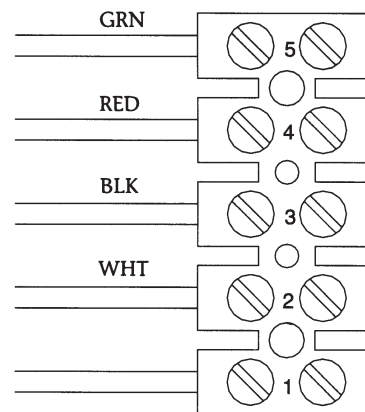

Figure 2

8. Attach power wires to the terminal block. See 240V wiring diagram inside the control enclosure cover. Attach the wires as follows:
 - White wire to terminal #2
 - Black wire to terminal #3
 - Red wire to terminal #4
 - Green wire to terminal #5
9. Complete the conductor connections at the power supply panel.
10. Do *not* turn power on until instructed to do so in the "Starting and Using Your Spa" section.

**TB1****240-Volt Power Input****Note:**

Consult the Wiring Diagram on Page 53 for 240 Volt to 120 Volt conversion on the Lite Leader System Only.

FEATURES AND CONTROLS

• Spa At-A-Glance

- Spa At-A-Glance
- Equipment Compartment
- Power Pack
- Spa Side Control
- In-Spa Features

Your Emerald Whirlpool spa may be equipped with a variety of user controls and optional features. This section locates and describes each. Please take the time to recognize and understand the functions of these components and controls.

Spa At-A-Glance provides a pictorial overview of key user components.

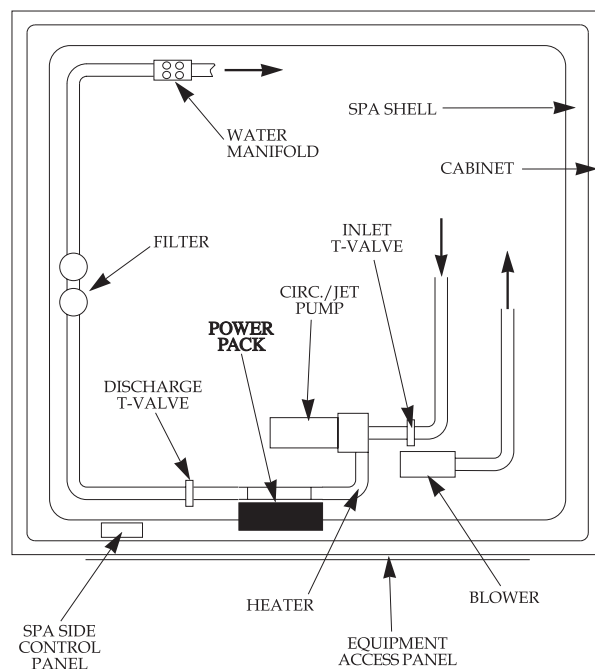

1 - Pump System

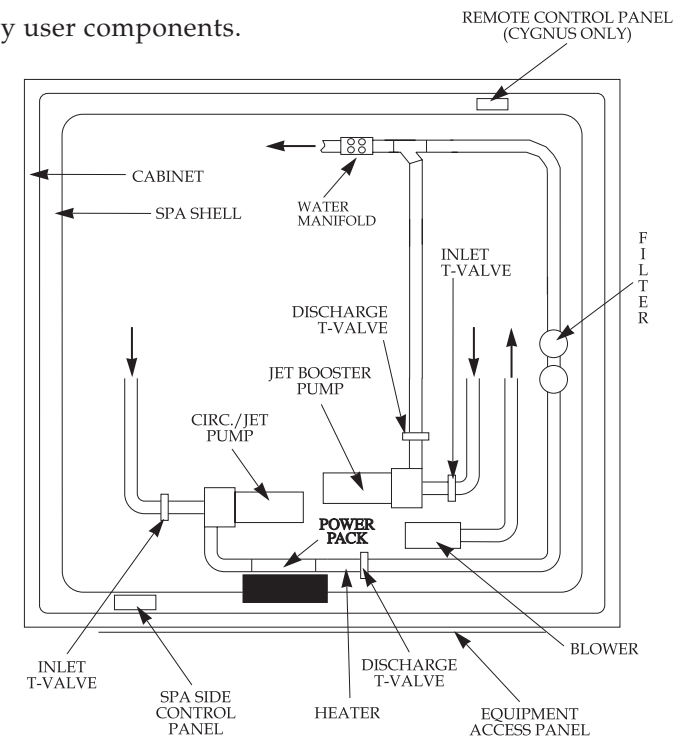

2 - Pump System

(These diagrams represent generic one pump and two pump systems. They are not intended to represent any specific model.)

● Equipment Compartment

The equipment compartment houses the "nerve center" of the spa and includes the following system components.

Pump(s)

Emerald Spas have different pump systems, depending on the spa model. Emerald Base, Classic and Special Edition spas have a two-speed (circulation/jets) pump and provide:

- Filtration, circulation and heat on low speed.
- Hydrotherapy jet action on high speed for 120V. For 240V, the spa will also heat in high speed.

The Emerald Elite and Cygnus series have a two pump system which uses an additional booster pump to enhance jet action.

Blower

Emerald Classic, Elite, Special Edition and Cygnus spas include a blower to provide bubble therapy and an enhanced force of air to the water jets called High Performance-Jet Select.



Caution:

T-valves must be open when spa is in use. See Fig. 1.

T-valves must be in closed position before any plumbing is disassembled for service. See Fig. 2.

T-valves

All one-pump systems have two T-valves, located in the water circulation lines on either side of the power pack. Some models have two pumps, which include two additional T-valves located on either side of the booster pump.

To operate T-Valve:

- To close, temporarily remove security clip and push T-handle down.
- To open, pull T-handle up and secure with security clip.

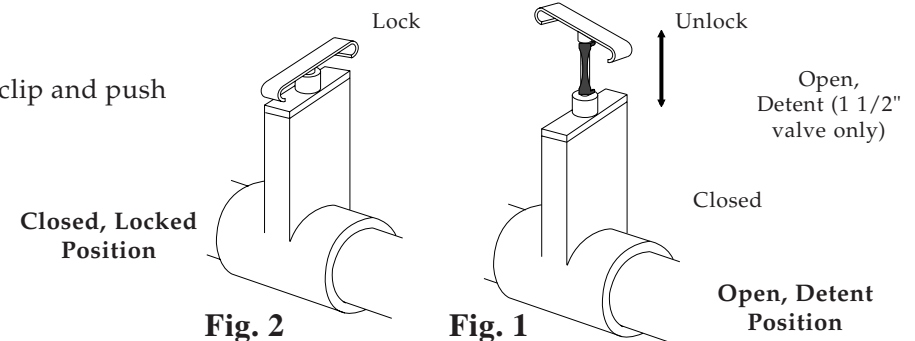

● Power Pack

One-Pump System

Below is a general description for the one pump system of the Lite Leader, SS-1D, and SS-3D used in your Emerald spa.

- | | |
|--|------------------------------|
| 1. control panel - (SS-3D shown) | 10. connector plumbing elbow |
| 2. temperature sensor | 11. heater |
| 3. ozone generator (optional) | 12. control outputs |
| 4. light | 13. power pack |
| 5. 2-speed circulation/jets pump | 14. water outlet T-valve |
| 6. water inlet T-valve | 15. water outlet line to spa |
| 7. water inlet line from spa | 16. ozone tee |
| 8. air line from blower to spa
(not on Base Models) | 17. grounding wire |
| 9. air blower
(not on Base Models) | |

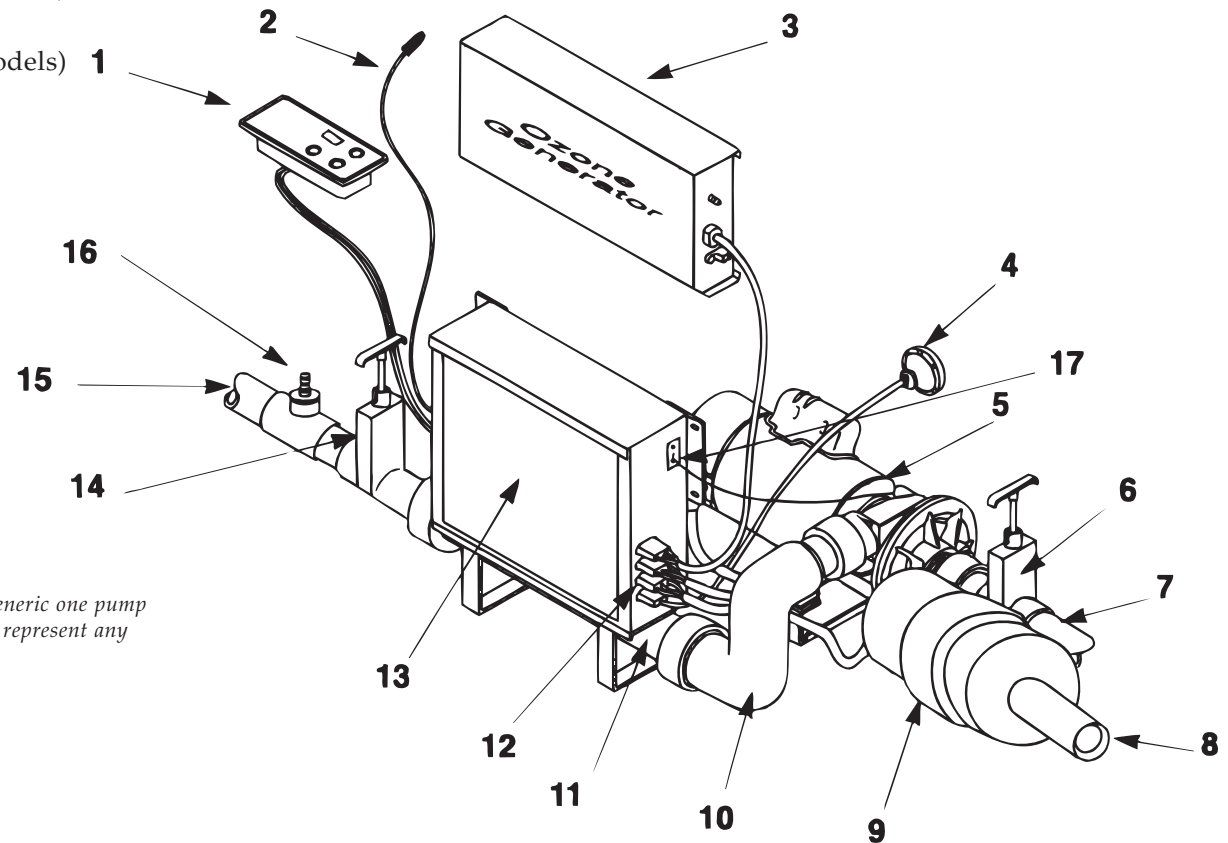

This diagram represents a generic one pump system. It is not intended to represent any specific model.

● Power Pack (continued)

Two-Pump System

All Emerald Elite and Cygnus Series models use a two pump system. The following is a general description of this system.

1. control panel - (DS-4 shown)
2. temperature sensor
3. water inlet T-valve - pump 1
4. 2-speed circulation/jets pump
5. ozone generator (optional)
6. light
7. booster pump - pump 2
8. water outlet T-valve - pump 2
9. water outlet line to manifold
10. water inlet line from spa-pump 2
11. water inlet T-valve - pump 2
12. air line from blower to spa
13. air blower
14. ozone tee
15. control outputs
16. heater
17. power pack
18. connector plumbing elbow
19. water outlet T-valve - pump 1
20. water inlet line from spa - pump 1
21. Auxillary control panel - (DS-4 only)
22. grounding bar
23. water outlet line to spa

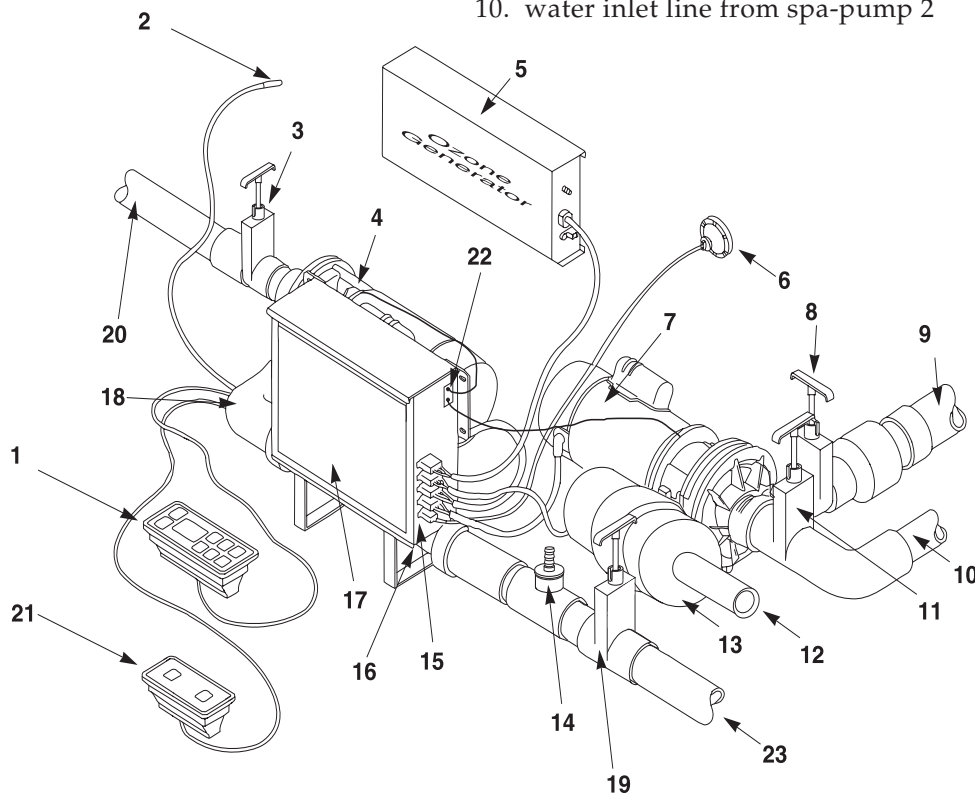

This diagram represents a generic two pump system. It is not intended to represent any specific model.

The Features of each Power Pack are Summarized in the Following Chart:

	Lite Leader	SS-1D	SS-3D	DS-2	DS-4
Pump	1.5 hp, 2speed	4.8 hp, 2speed	4.8 hp, 2speed	(1) 3.65hp & (1) 2hp	(1) 3.65hp & (1) 3.5hp
Heater	1.0/4.0KW	5.5KW	5.5KW	5.5KW	5.5KW
Blower	No	No	1hp	1hp	1hp
Light	Yes	Yes	Yes	Yes	Yes
Control Panel	Digital	Digital	Digital	Digital	Digital
Ozonator (optional) 120V	Ready	Ready	Ready	Ready	Ready
Voltage Requirement	240V(120v opt.)	240V	240V	240V	240V
Temperature Adjustment	Keypad	Keypad	Keypad	Keypad	Keypad
Automatic Time Outs	Yes	Yes	Yes	Yes	Yes
Preset Filter Cycles	Yes	Yes	Yes	Yes	Yes
Programmable Filter Cycles	Yes	Yes:Topside	Yes:Topside	Yes:Topside	Yes:Topside
Sensor Failure Detection	Yes	Yes	Yes	Yes	Yes
Flow Switch Error Detection	Yes	Yes	Yes	Yes	Yes
Freeze Protection	Yes	Yes	Yes	Yes	Yes
High Limit Protection	Yes	Yes	Yes	Yes	Yes
High Limit Reset	Topside	Topside	Topside	Topside	Topside
Heater/Status Indicator	Yes	Yes	Yes	Yes	Yes
Night Vision Backlight	No	No	No	No	Yes
Continuous Digital H ² O Temperature Display	Yes	Yes	Yes	Yes	Yes
Digital Time Display	No	No	No	No	Yes
Icon Representation of Functions	No	No	No	No	Yes
Digital Operational Status Display (std. & econ.)	No	No	No	Yes	Yes
Digital Diagnostic Display	Yes	Yes	Yes	Yes	Yes
Automatic Filtration	Yes	Yes	Yes	Yes	Yes
Automatic Air Injector Purge	No	No	Yes	Yes	Yes
Automatic Clean-Up Cycle	No	No	No	Yes	Yes
Temperature Lock	No	No	No	No	Yes
Panel Lock	No	No	No	No	Yes
Battery Back-Up Program Saver	No	No	No	Yes	Yes
Remote Control Panel (Option)	No	Yes	Yes	Yes	Yes
High Performance Jet Select	No	No	Yes	Yes	Yes
Standby Mode (Pump disable)	No	No	No	Yes	Yes
Optional Freeze Sensor Input	No	Yes	Yes	Yes	Yes
Fiber Optic Lighting Capable	No	No	No	Yes	Yes

- **Spa Side Control
Lite Leader**

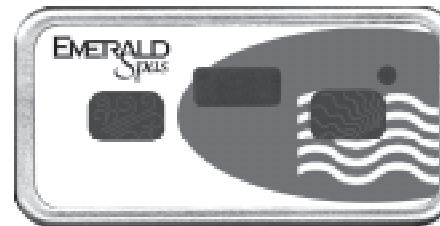

Start-up

Your Lite Leader control has been specifically designed so that by simply connecting the spa to its properly grounded source, the control will automatically heat the water to the set temperature. Your spa equipped with the Lite Leader is shipped in the 240V configuration. See the Lite Leader schematics on page 53 if you plan to convert the Lite Leader power system to a 120V configuration.

Temperature Adjustment (80° F - 104° F)

Temperature adjustment is controlled by pushing the  pad. The display shows the actual water temperature unless the pad is pressed. When the pad is pressed, the display will show the set temperature. Pressing the pad a second time will cause the set temperature to increase or decrease depending on what direction was last chosen. Each successive press will change the set temperature in the same direction.

If the opposite direction is desired, release the pad and let the display revert to the actual water temperature again. Press the pad to display the set temperature, and again to make the temperature change in the desired direction.

Light and Jets Keypad

Press the  pad once to turn on the light. Press the pad again and the low-speed pump, light and ozone generator (if installed) will operate. Press the pad a third time and the high-speed pump and light will run. Press the pad again and only the high-speed pump will be on. Press the pad a final time to turn off all functions. The light will automatically turn off after 4 hours of operation. The low-speed pump and ozone generator (if installed) turn off after 2 hours, and the high-speed pump turns off after 15 minutes of operation. The low-speed pump starts automatically when the heater is turned on. If automatically activated, the low-speed pump cannot be turned off with the function pad; however, the high-speed pump may be started.

- **Spa Side Control
Lite Leader**
[continued]

Preset Filter Cycles

Your Lite Leader will automatically filter itself twice each day. The first filter cycle will begin 1 minute after the Lite Leader is energized. The second filter cycle will begin 12 hours after the start of the first filter cycle. The filter cycle is set by the dealer for 2 or 5 hours. The low-speed pump and ozone generator (if installed) will run during filter cycles.

Center Display Messages

These are some of the messages you may see on the center display.

OH **Overheat** (Spa is deactivated)
The spa has shut down. **DO NOT ENTER THE WATER!** Turn off all power to the spa and call your dealer or service organization. To reset the spa, press any panel button.

FLO **Flow**
A pressure switch is not working. Call your dealer or service organization.

Snl **Sensor**
The high-limit sensor or water temperature sensor is not working. Call your dealer or service organization.

- **Spa Side Control Panel SS-1D**

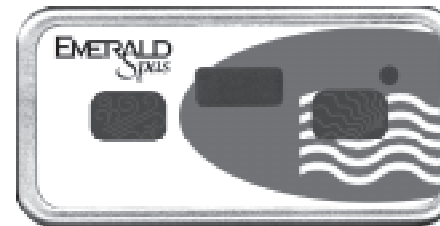

Start-up

When your spa is first powered up, it will automatically heat and maintain 100° F until you change the set temperature. Immediately after start-up, the spa will begin a 3 hour filter cycle to clean the water. To select a different duration, see "Preset Filter Cycles" below.

Temperature Adjustment (60° F - 104° F)

Press the  pad to display the temperature previously set. Pressing the pad a second time will cause the set temperature to increase or decrease depending on what direction was last chosen. Each successive press will change the set temperature in the same direction.

If the opposite direction is desired, release the pad and let the display revert to the actual water temperature again. Press the pad to display the set temperature, and again to make the temperature change in the desired direction.

Light and Jets Keypad





Touch the  pad once to turn on the spa light. Touch the pad again, and the light, low-speed pump, and ozone generator (if installed) will operate. Press the pad a third time, and the light and the high-speed pump will run. Press the pad again, and only the high-speed pump will run. Press the pad again to turn the high-speed pump off. The light will automatically turn off after 1 hour of use. The low-speed pump and ozone generator (if installed) turn off after 2 hours, and the high-speed pump after 15 minutes. The low-speed pump starts automatically when the heater is turned on. If automatically activated, the low-speed pump cannot be turned off with the function pad; however, the high-speed pump may be started.

Preset Filter Cycles

Your spa will automatically filter itself for 3 hours, twice each day. The first filter cycle will start one minute after the spa is powered up. The second filter cycle will begin twelve hours later. The low-speed pump and ozone generator (if installed) will run during filter cycles.

- **Spa Side Control Panel SS-1D**
[continued]

Setting the Filter Cycles - SS-1D ONLY

The filter cycle duration is programmable via the topside panel. Press the  pad, then the  pad, and "F3" will be displayed on the panel. "F3" is the default filter time and indicates a 3 hour cycle. Press the  pad again to cycle through the rest of the filter time options; "F6" = 6 hours, "F9" = 9 hours, and "FC" = 12 hours. After you have selected your duration, press the  pad again to exit the programming.

Center Display Messages

These are some of the messages you may see on the center display.

OH

Overheat (Spa is deactivated)

The spa has shut down. DO NOT ENTER THE WATER! Turn off all power to the spa and call your dealer or service organization. To reset the spa, press any panel button.

FLO

Flow

A pressure switch is not working. Call your dealer or service organization.

Snl

Sensor

The high-limit sensor or water temperature sensor is not working. Call your dealer or service organization.

- **Spa Side Control Panel SS-3D**

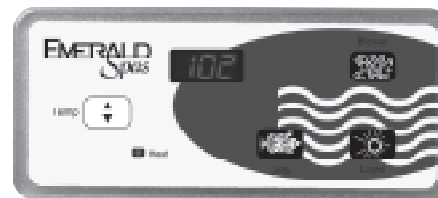

Start-Up

Your spa control has been specifically designed so that by simply connecting the spa to its properly grounded source, the spa will automatically heat to the set temperature.

Temperature Adjustment (60° F - 104° F)

Spa temperature is controlled by pressing the "Set" pad. The display shows the actual water temperature unless the pad is pressed. When the pad is pressed, the display will show the set temperature. Pressing the pad a second time will cause the set temperature to increase or decrease depending on what direction was last chosen. Each successive press will change the set temperature in the same direction.

If the opposite direction is desired, release the pad and let the display revert to the actual water temperature again. Press the pad to display the set temperature, and again to make the temperature change in the desired direction.

Jets Keypad

Touch the "Jets" pad once to activate the low speed pump. Touch the pad again to activate the high-speed pump. Press the pad a third time to deactivate the pump. The low-speed pump starts automatically when the heater is turned on, when a filter cycle is activated, or when a freezing condition is detected. If automatically activated, the low-speed pump cannot be disabled from the front panel; however, the high-speed pump may be started. Whenever the low-speed pump is energized with this pad, it will automatically turn off after 2 hours. The high-speed pump turns off after 15 minutes.

Air Keypad

Press the "Blower" pad to turn the air jets on and off. The air jets will automatically turn off after 15 minutes of use.

Light Keypad

Press the "Light" pad to turn the spa light on and off. The spa light will automatically turn off after 1 hour.

- **Spa Side Control Panel SS-3D**
(Continued)

Preset Filter Cycles

Your spa will automatically filter itself twice each day. The first filter cycle will begin one minute after the spa is energized. The second filter cycle will begin twelve hours later. To clean out the blower lines, the air jets will run for 30 seconds at the start of the first filter cycle. During filtration, the low-speed pump will activate. The ozone generator (if installed) will run 24 hours per day, but is assisting with water purification only when the pump is running. Filter duration is programmable via the topside panel.

Setting the Filter Cycles

Press the "Set" pad, then the "Jets" pad, and "F3" will be displayed on the panel. "F3" is the default filter time and indicates a 3 hour cycle. Press the "Set" pad again to cycle through the rest of the filter time options; "F6" = 6 hours, "F9" = 9 hours, and "FC" = 12 hours. After you have selected your duration, press the "Jets" pad again to exit the programming mode.

Safety Features

Overheat Protection (Spa is deactivated)

If your spa should overheat, the display will flash {OH}. In such a condition, DO NOT ENTER THE WATER. Turn off all power to the spa and contact your dealer or service organization. Overheating may also occur if the filter duration is set too long at the time of installation. To reset the spa, press any panel button.

Flow Switch Detection

If a pressure switch malfunctions, the display will show {FL}. Contact your dealer or service organization.

Open Sensor (Spa is deactivated)

If the high-limit sensor or water temperature sensor malfunctions, the display will show {Sn}. Contact your dealer or service organization.

- Spa Side Control Panel DS-2



Start-up

Your spa control has been specifically designed so that by simply connecting the spa to its properly grounded source, the spa will function properly and safely at 100° F. When your spa is first activated, the LCD will display the current spa temperature and COOL in the display window if the water is 20° F cooler than the set temperature. During each filter cycle, the spa will heat to the set temperature.

User's Keypads

Temperature Controls (60° F - 104° F)



The current temperature is constantly displayed on the LCD. Press either the up (warm) or down (cool) arrows once to display the set temperature. (The set temperature is designated by a triangle in the upper left corner.) Each time either pad is pressed again, the set temperature will increase or decrease depending upon which pad is pressed. After three seconds, the LCD will automatically display the current spa temperature.

Jets Keypad



Touch this pad once to activate the low-speed pump. Touch again to activate the high-speed. Press the pad a third time and the second pump will also activate. Press the pad again to deactivate the pump(s). The low-speed pump starts automatically when the heater is turned on, when a filter cycle is activated, or when a freezing condition is detected. If automatically activated, the low-speed pump cannot be turned off with the "jets" pad; however, the high-speed pump may be started. When the low-speed pump is started with this pad, it will automatically stop after 2 hours and 20 minutes of operation. The high-speed pump will stop after 15 minutes.

Blower Keypad



Touch the blower keypad to activate the first speed of the blower (high). Press the pad again to activate the second speed of the blower (low) and once again to turn the blower off. The blower will automatically turn off after 15 minutes.

Light Keypad



Press this pad to operate the light cycle. The light will automatically turn off after 1 hour of operation. If your spa is equipped with optional fiber optic lighting, then 4 colors will cycle once you press the light keypad. To stop on a desirable color press the light keypad a second time. To turn the fiber optic lighting off press a third time.

- **Spa Side Control Panel DS-2**
(continued)

Standard or Economy Mode

Press this pad to switch between modes. Economy mode only heats the water during filter cycles. Standard mode maintains the desired set temperature at all times.

Filter Cycles

Your spa will automatically filter itself twice a day. The first filter cycle will start one minute after the spa is powered up. The second filter cycle will begin twelve hours later. The blower will run for 30 seconds at the start of the first cycle to clean out the air lines. The low-speed pump will run during filter cycles (unless the high-speed pump is activated) and the heater will be on. The ozone generator (if installed) will run 24 hours per day, but is assisting with water purification only when the pump is running. Filter cycle duration is programmed via the topside panel for 3, 6, 9 or 12 hours. To program, press the "Warm" or "Cool" pad, then press the "Mode" pad. Press the "Warm" or "Cool" pad again to select the duration of the twice-daily cycle. Press the "Mode" pad to program the heater to enable or disable during filter cycles.

Cleanup Cycle

The low-speed pump turns on 20 minutes after the jets pad is pressed. The cleanup cycle runs for 2 hours.

Disabling Pumps

In times when you are entertaining or relaxing in the area of your spa, you can turn off the pump to avoid hearing any spa operational noise due to filtering or ozonating. To do this press the "Warm" or "Cool" pad, then the "Light" pad, and all spa functions will be disabled except for freeze control. To resume spa operation, press any panel button.

Center Display Messages

These are some of the messages you may see on the center display.

STAN**Standard**

The spa is in standard mode. StAN is flashed alternately with the current spa temperature and COOL until the spa water is 20° F cooler than the set temperature.

ECON**Economy**

The spa is in economy mode. ECON is flashed alternately with the current spa temperature and COOL until the spa water is 20° F cooler than the set temperature.

- **Spa Side Control
Panel DS-2**
(continued)

OH**Overheat protection**

If a malfunction occurs and spa water reaches 112° F, or the high-limit sensor has detected 118° F at the heater the spa is deactivated. In such a condition, **DO NOT ENTER WATER!** Remove the spa cover and allow the water to cool. At 110° F the spa should automatically reset. If the spa does not reset, shut off power to the spa and call your dealer or service organization.

ICE**Freeze protection**

If a freeze condition is detected, the pumps are automatically activated. This is a normal spa function; no action is necessary. Freeze protection is enabled regardless of the spa's status.

FLO**Flow switch**

If *constantly displayed*, a pressure switch has malfunctioned. Contact your dealer or service organization. If the flow message is *flashing*: the filter may need cleaning, the water level may be low, or the T-valves may need to be opened.

COOL**Temperature set back**

If spa water is more than 20° F cooler than the temperature last set, no action is required. Spa is functioning properly.

S_{n1}**Open Sensor**

Spa is deactivated. The high-limit temperature sensor is not working. This must be repaired only by a dealer or a qualified service organization.

S_{n3}**Open Sensor**

Spa is deactivated. The water temperature sensor is not working. This also must be repaired by a dealer or qualified service organization.

LOC**Standby**

Spa is deactivated. The spa can be shut down when the filter needs to be replaced. Press the "Warm" or "Cool" pad, then the "Light" pad, and all spa functions will be disabled except for freeze control. Press any panel button to resume spa operation.

- **Spa Side Control Panel DS-4**



Start-up

When your spa is powered up, it begins running in standard mode, which automatically heats and maintains the water at 100° F. Pressing the # pad switches the spa from standard mode to economy mode. This setting is designed for periods of little or no use, but continues to filter twice a day and maintains water quality.

General Description

Your Control panel consists of three main parts:

1. User's Keypads

Temperature Controls (60° F - 104° F)



When either of these pads is touched once, the LCD will display the temperature which has been set, as well as the words "SET HEAT". Each time either of these pads is pressed again, the set temperature will increase or decrease, depending on which pad is pressed. After 3 seconds, the LCD will automatically display the spa temperature.

Jets Keypad



Touch this pad once to activate the low-speed pump. Touch again to activate the high-speed. Press the pad a third time and the second pump will also activate. Press the pad again to deactivate the pump(s). The low-speed pump starts automatically when the heater is turned on, when a filter cycle is activated, or when a freezing condition is detected. If automatically activated, the low-speed pump cannot be turned off with the "jets" pad; however, the high-speed pump may be started. When the low-speed pump is started with this pad, it will automatically stop after 2 hours and 20 minutes of operation. The high-speed pump will stop after 15 minutes.

Blower Keypad



Touch the blower keypad to activate the first speed of the blower (high). Press the pad again to activate the second speed of the blower (low) and once again to turn the blower off. The blower will automatically turn off after 15 minutes.

- ## Spa Side Control Panel DS-4

(continued)

Light Keypad



Press this pad to operate the light cycle. The light will automatically turn off after 1 hour of operation. If your spa is equipped with optional fiber optic lighting, then 4 colors will cycle once you press the light keypad. To stop on a desirable color press the light keypad a second time. To turn the fiber optic lighting off press a third time.

Time



Press this pad to view time of day and press again to view temperature. Current spa temperature display will automatically resume after 3 seconds.

2. Liquid Crystal Display

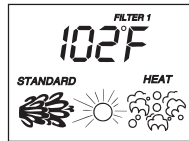

This display continually shows operating status of the spa, as well as the various monitoring functions and programming information.

3. User's Program Keypads

Program function

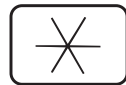

This pad initiates time setting, 7-day programming, 24-hour pump operation and panel lock routines.

Mode function



Press this pad to switch spa operation to either the Economy or Standard mode. When the Economy mode is selected, the heater will maintain a temperature of 20° F below the preset temperature. In the Standard mode, the preset spa temperature will be maintained. This pad also resets the control in the event of an overheat display message (see Center Display Messages).

Automatic Operations

Preset Filter Cycles

Your spa filter cycles are pre-programmed from the factory to automatically filter for a 3-hour period every 12 hours. The first filter cycle is automatically activated at 2:00 AM and runs till 5:00 AM. The second cycle is between 2:00 PM and 5:00 PM. During these cycles the heater will operate in the economy mode.

- **Spa Side Control
Panel DS-4**
(continued)

Optional Filter Cycles

While you are not required to set filter cycles, if you want to change them, press the time pad, and the star (*) pad twice all within 3 seconds. "SET START FILTER 1" (AM cycle) will appear on the display.

Press the "Warm" or "Cool" keypad to reset the filter start time.

When "SET HEAT" is on the display, press the "Warm" pad to enable or press the "Cool" to disable the heater during filtering.

Press the star (*) pad to see "STOP FILTER 1" and adjust the time with the "Warm" or "Cool" pad as done above.

Press the star (*) pad to see "START FILTER 2" (PM cycle) and proceed as above.

Pressing the mode (#) pad will enter the new filter cycle times into the system and display the current water temperature.

Cleanup Cycle

Your spa has an automatic cleanup cycle which circulates and maintains the cleanliness of the water.

Twenty minutes after the "Jets" pad has last been pressed the cleanup cycle will begin. (Due to preset time-outs, the spa assumes that you are finished using the spa 20 minutes after the "Jets" pad is pressed.) During the clean up cycle, the circulating pump will turn on for a 2 hour period and the panel will display "FILTER".

If the "JETS" pad is pressed during the cleanup cycle, the cleanup cycle will shut off. Twenty minutes after the "JETS" pad is pressed, the cleanup cycle will begin again.

Disabling Pumps

In times when you are entertaining or relaxing in the area of your spa, you can turn off the pump to avoid hearing any spa operational noise due to filtering or ozonating. To do this press the "Time" then "Down" button and ILOC will appear on the display, and all spa functions will be disabled except for freeze control. To resume spa operation, press any panel button.

Invert Temperature Display

To view the temperature display from the inside of the spa or from the outside, press the "TIME" pad then the ▲ or ▼ for either direction.

- **Spa Side Control Panel DS-4**
(continued)

Programming

Initial Start-up

Your Spa Control has been specifically designed so that by simply connecting the spa to its properly grounded source and touching the Mode [#] pad, the spa will function properly and safely at 100° F. In this mode, all user pads will be completely functional. The spa will just about take care of itself. However, to fully utilize the unique capabilities of the control, it is important to set the time of day and the day of the week properly.

Setting the Time

Once the spa has been properly connected, notice the "SET TIME" message flashing on the screen.

PRESS  THEN 



OR  After either pad is pressed once, hours will advance or decrease automatically in one-minute increments. Press either pad again to stop the display's time-setting cycle.

Panel Lock

To help prevent unauthorized use of your spa, the Cygnus control has incorporated a unique panel locking system. When the panel lock is engaged, all automatic spa functions will operate normally.

To lock the panel

These pads must be pressed in the correct sequence and within 3 seconds to activate the lock. When locked, the center display will show the spa temperature along with the lock symbol. All the pads are now deactivated except the program pad, which is used to initiate the unlock sequence.

PRESS  THEN  THEN 

THE CENTER DISPLAY WILL READ



- Spa Side Control
Panel DS-4
(continued)

To unlock the panel

These pads must be pressed in the correct sequence and within 2 seconds to unlock the panel. When the last pad is pressed, the lock symbol will disappear. All pads are now active.

PRESS  THEN  THEN 

Temperature Lock

The temperature lock is provided to prevent unauthorized temperature adjustment of your spa water. While setting your spa water temperature, immediately after you pressed ▲ or ▼, follow the instructions below to lock the set temperature. When the temperature lock is engaged, all automatic spa functions will operate normally.

To lock the temperature

These pads must be pressed in the correct sequence and within 3 seconds to activate the temperature lock. When locked, the center display will show the spa temperature, the lock symbol, and the words "SET HEAT". The temperature pads will be deactivated; when pressed, the set temperature will appear with a double arrow next to it.

THE CENTER DISPLAY WILL READ

PRESS  THEN  THEN 

LOC° F
0

To unlock the temperature

These pads must be pressed in the correct sequence and within 2 seconds to unlock the temperature. When the last pad is pressed, the lock symbol will disappear. All pads are now active.

PRESS  THEN  THEN 

- Spa Side Control
Panel DS-4**
(continued)

Center Display Messages

These are some of the messages you may see on the center display.

LOV

Interlock (Some models only)

Spa is deactivated. Designates a self-protective mode when low voltage or supply noise is present. Press the Mode [#] pad to reset.

Pd

Battery backup

Power has been cut off to the spa, and it is using its battery backup to preserve its settings [15 to 20 minutes]. The control panel will be disabled until power returns to the unit.

OH

Overheat protection

Spa is deactivated. If a malfunction occurs and spa water reaches 112°F, the system will completely shut down. In such a condition, DO NOT ENTER WATER! Turn off all power to the spa and contact your dealer or service organization. Overheating may also occur if you set the low-speed pump to operate for extended periods of time in Economy mode. In this instance, remove the spa cover and allow the water to cool to below 110°F. Touch the mode [#] pad to reset the system. If the water is still hotter than the set temperature, touch the blower pad to cool the spa.

ICE

Freeze protection

If a freeze condition is detected, both pumps are automatically activated. This is a normal spa function; no corrective action is necessary. Freeze protection is enabled regardless of the spa's status.

FLO

Flow switch

If *constantly displayed*, a pressure switch has malfunctioned. Contact your dealer or service organization. If the flow message is *flashing*: 1- The filter may be plugged. Remove the filter and clean. 2- The amount of water may be inadequate. Be sure the spa is properly filled. 3- A pressure switch has malfunctioned. The spa will operate, but the heater will not activate. Contact your dealer or qualified service organization.

COOL

Temperature set back

If spa water is more than 20° F cooler than the temperature set point, the heater will automatically activate to provide freeze protection. This is a normal function; no corrective action is needed.

Sn1

Open Sensor

Spa is deactivated. The high-limit temperature sensor is not working. This must be repaired only by a dealer or a qualified service organization.



Sn3

Open Sensor



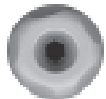
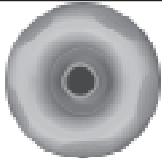

Spa is deactivated. The water temperature sensor is not working. This also must be repaired by a dealer or qualified service organization.

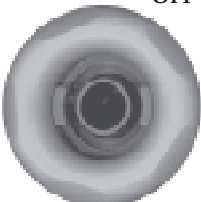
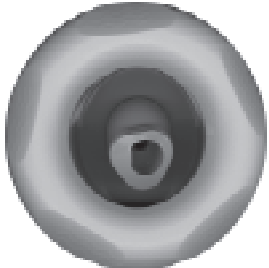
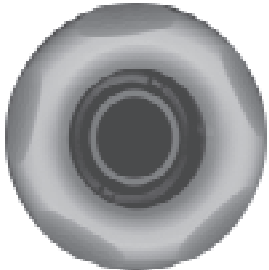
● **In-Spa Features**

Your spa may be equipped with a variety of therapy jets, controls, and fixtures. Refer to the following charts and identify those features installed on your spa. NOTE: take care not to turn the jet face beyond the natural stopping point. If this does occur it may prevent the jet from functioning properly.

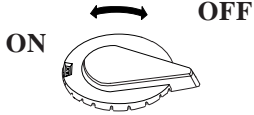
Therapy Jets and Controls		
Duo Jet	Duo jets are 100% flow and are used in the Emerald Captain's chair, and various other locations in some Emerald models.	
Micro Magna Jet	The Micro allows the barrel to be positioned to deliver pinpoint therapy to a location. Turn the outer ring to also moderate the water flowing through the jet.	ON  OFF
Magna Rotating Swirl Jet Magna Directional Jet	The Magna swirl jet rotates 360 degrees at a rapid rate thus massaging a larger area. Turn the outer ring to also moderate the water flowing through the jet. The Magna directional allows the barrel to be positioned to deliver a broad therapy to a specific location. Turn the outer ring to also moderate the water flowing through the jet.	ON  OFF 
VSR (Variable Swirl Jet)	The VSR features a controllable velocity of water in either a straight position or in a rotation. Simply take your finger and click the barrel of the jet down to cause the nozzle to move in a rotational pattern.	ON  OFF
Turbo-Jet and Turbo Air Control (Cygnus feature only) Note: Other jets may not operate when the turbo-jet is on.	The turbo-jet can provide intense localized hydrotherapy or create a gentle whirlpool effect. Turn the outer ring to the left for "On" and right for "Off". Adjust the inner nozzle to control the direction of the water flow. Open or close the turbo air control (see air control valves Pg. 34) to adjust the amount of air mixed with the water flow. More air adds to the massage effect.	ON  OFF

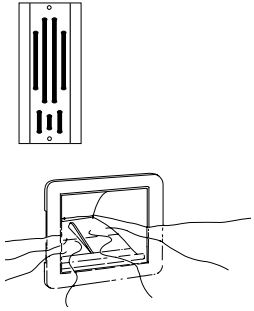
Other Controls and Fixtures

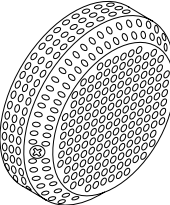
<p>Air Control Valves</p>	<p>The air intake valves are located near the spa side control panel. Turn to increase or decrease the amount of air mixed with the water flow. More air adds to the massage effect.</p>	
<p>Light</p>	<p>This fixture is controlled by the "Light" button on the SS-3D, DS-2 and DS-4 panels. With the Lite Leader and SS-1D, see the Lights and Jets section on page 18 for the Lite Leader control and page 20 for the SS-1D. (Optional Fiber Optics pictured to the right).</p>	
<p>Air Injectors (Not available on Lite Leader & SS-1D controls)</p>	<p>When the blower is on, air bubbles are released from the injectors primarily located on the lounge seat and the footwell. These injectors create a mild vibrating effect that massages the body.</p>	
<p>Strip Skimmer (Emerald Base & Emerald Classic)</p> <p>Weir Skimmer (Emerald Special Edition, Elite & Cygnus Series)</p>	<p>This skimmer is found on Emerald Base and Classic models featuring Lite Leader, SS-1D and SS-3D controllers. Its purpose is to skim the water surface. Always keep the water level at least 2/3 high on the skimmer or damage to the system may result.</p> <p>This skimmer is found on Emerald Elite (DS-2 controller), Special Edition (SS-3D controller) and Cygnus Series (DS-4 controllers). Its purpose is to skim the water surface. Always keep the water level at least half way up the opening of the skimmer or damage to the system may result.</p>	
<p>Aromatherapy Option (NOT an option on the Emerald Base)</p>	<p>To use the aromatherapy feature, unscrew the cap and, as the picture to the right demonstrates, place special aromatherapy pellets inside. The scent will be disbursed primarily while the blower is operating.</p>	
<p>Suction Grate</p>  <p>Warning: Never Block or remove the suction grate. Do not use spa if suction grate is removed!</p>	<p>The suction grate is the intake opening for the water circulating system. This grate protects you from the powerful suction created by the pump(s) that power your spa.</p>	

Starting And Using Your Spa

● Install Filter Elements

Note:

The Filter Key allows the loosening/tightening of the filter caps for filter/spa maintenance. The filter key's two parallel pegs are inserted into the filter cap and turned to the desired open/closed operation. The removal hook aids in lifting the elements from the interior of the filter.

- Install Filter Elements
- Proper Water Level
- Bleeding Air
- Testing the GFCI
- One-Pump Priming
- Two-Pump Priming
- Setting the Thermostat

Placing elements in the Filter

1. Unpackage the filter elements located inside the cabinet to be inserted into the filter.
2. Unscrew the top of the filter canister located on the top of the coping and insert the element with the largest hole into the appropriate filter housing.
3. Insert the element with the smaller hole into the filter housing that accepts it.
4. Insert the Filtering Assist Plug into the middle of the filter element with the smallest hole. (This procedure allows for water to penetrate into the interior pleats of the element allowing for optimal filtration.)

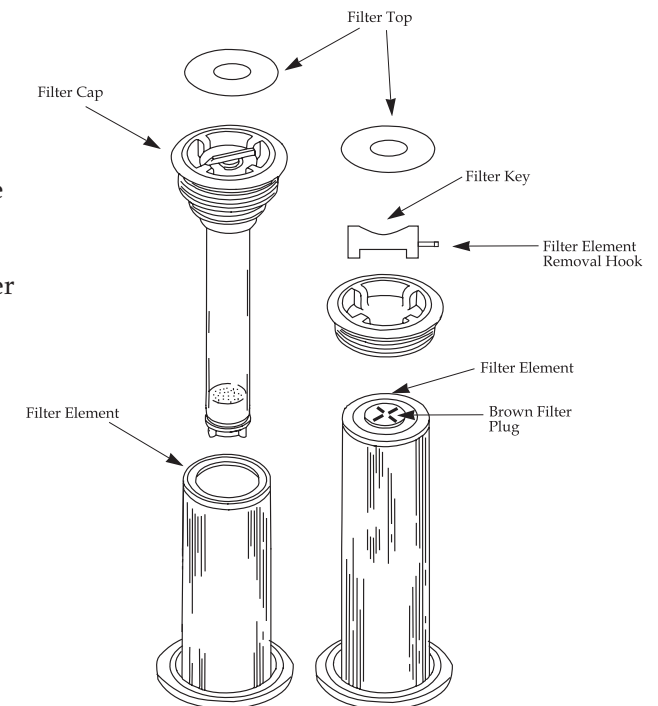

• Proper Water Level



Caution:

Low water level can damage the water circulating system and void your warranty. Read and understand all safety, location, and installation instructions before proceeding.

Add water until level is at appropriate level for your model's skimmer (see page 34) or damage to system may result.

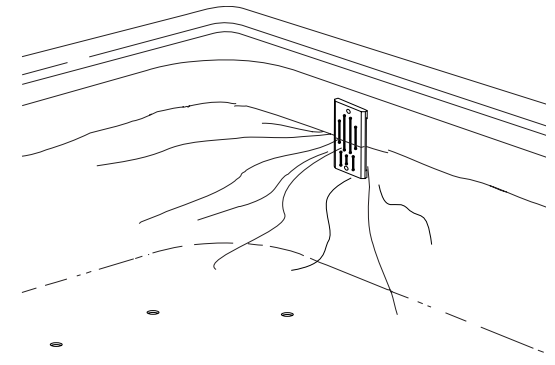

• Bleeding Air



Caution:

Air must be bled from the system. Air in the system can damage the spa and void the warranty.

1. While the spa is off use the filter key to unscrew and remove the filter caps. This allows for the large pocket of air naturally formed when the spa was filled with water to escape from the filter cavity.
2. Once the water level inside the filter housing has reached the same level as the water inside the spa you can then replace the filter caps.
3. Tighten the filter cap snugly using the filter key. Be sure not to overtighten. When the spa is running, you should not see or hear any water leaking from the spot where the filter top meets the housing. If you see or hear water escaping turn the spa off and retighten the filter lid.

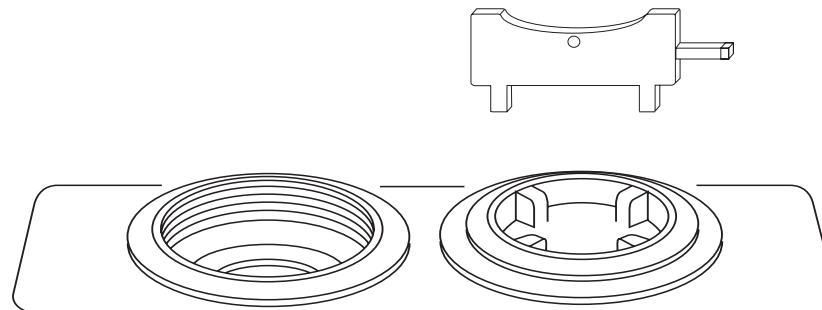

- **Testing the GFCI**
[for spas equipped with Lite Leader (240V) SS-1D, SS-3D, DS-2, and DS-4]

Your spa must be provided with a GFCI-circuit breaker located in the power supply panel as installed by your electrician. Turn on the circuit breaker and test the GFCI by pushing the test button. A red indicator should appear and your spa should stop operating. Push the reset button and the red indicator should disappear. The spa should begin to operate normally.



WARNING:

If the GFCI fails to operate in this manner, there is a risk of electric shock! Shut off the main power source. Identify and correct problem before using the spa.

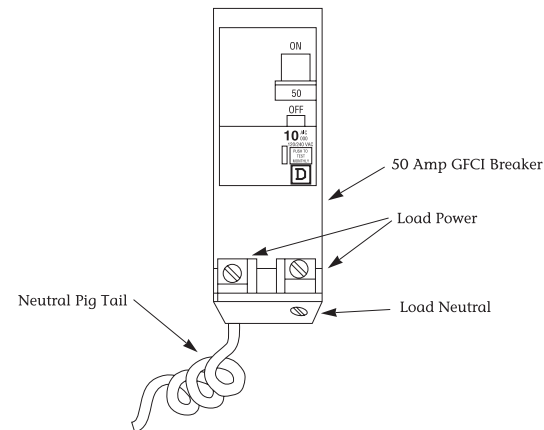

- **One pump Priming**
[for spas equipped with Lite Leader, SS-1D, and SS-3D]



Caution:

Never run the system without circulating water. Doing so can damage the pump and void the warranty.

1. Press the "Jets" key pad. The pump will begin to operate in the high-speed mode; this will facilitate pump priming.
2. When your jets begin to operate vigorously, the pump is

Note:

If water does not flow within a minute or two, turn off power to the spa and repeat steps for bleeding the air.

- **Two-Pump Priming**
[for spas equipped with DS-2 and DS-4]

Note:

If water does not flow within a minute or two, turn off all power to the spa and repeat steps for bleeding air.

**Caution:**

Never run the system without circulating water! Doing so can damage pumps and void the warranty.

Each pump must be primed separately. To accomplish this, follow these steps.

1. Press the "Jets" key pad twice. The circulating/jets pump will operate in the low speed mode on the first press and in the high speed mode on the second press. The high speed mode will facilitate pump priming.
2. When the jets begin to operate moderately, the circulating/jets pump is completely primed.
3. Now press the "Jets" key pad a third time. The jets booster pump will now operate.
4. When the jets begin to operate more vigorously, the jets booster pump is completely primed. If you do not see any distinguishing difference in jet flow when pressing the "Jets" button a third time then the booster pump may require direct priming.
 - A. Remove the equipment panel and locate the booster pump (see 2-pump system diagram on page 16).
 - B. With the booster pump running turn the pump drain plug counterclockwise until a steady stream of water appears. Once water appears quickly tighten the plug and you should notice a more intense flow of water through the jets.
 - C. If no noticeable difference has occurred repeat step B.

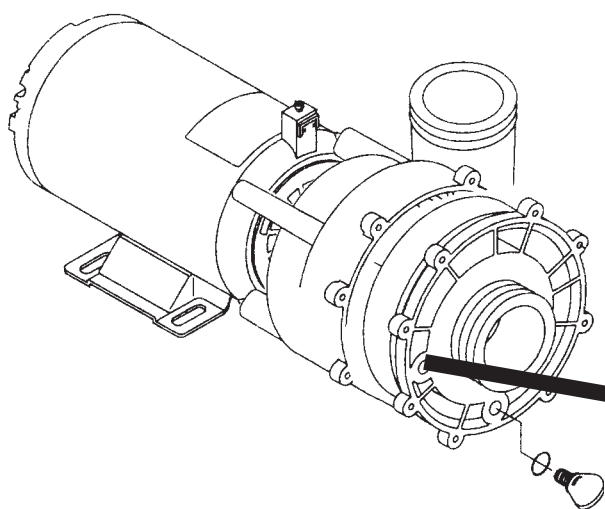

Water Line Connection goes to the jet

● Setting the Thermostat



WARNING:

Never use the spa at temperatures above 104° F.

Temperatures above 104° F or prolonged immersion may cause hyperthermia. [See "Important Safety Instructions" in the first section of this manual for a description of the symptoms and effects of hyperthermia.]

For Spas with a Lite Leader, SS-1D or SS-3D Power System: Press the thermostat button ("set" button for SS-3D) to display the temperature previously set. Pressing the pad a second time will cause the set temperature to increase or decrease depending on what direction was last chosen. Each successive press will change the set temperature in the same direction. If the opposite direction is desired, release the pad and let the display revert to the actual water temperature again. Press the pad to display the set temperature, and again to make the temperature change in the desired direction.

For Spas with a DS-2 or DS-4 Power System: Press the "Warm or Cool" temperature key pad until the digital readout indicates a thermostat set point of 95° F.

Note:

The hot setting on the thermostat will produce a temperature of approximately 104° F. Initially, operate your spa at 95° F and cautiously increase the temperature over a few day period as you become accustomed to its effect.

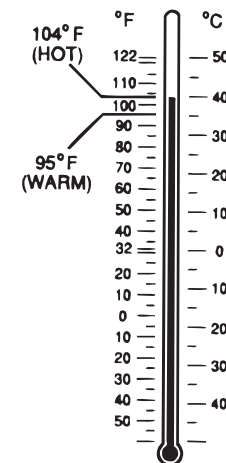

● Chemical Safety Tips

Note:

Check and maintain your water chemistry at least twice a week for proper levels (see page 41).

● Spa Capacity

Note:

Useable: at the level noted on skimmer full level (see page 34)

SPA WATER CHEMISTRY

- Chemical Safety Tips
- Spa Capacity
- pH Control
- Disinfecting Your Spa
- Ozone Generator
- Other Water Chemistry Considerations

- ✓ Never mix different types of chemicals or contaminate them in any way.
- ✓ Do not exceed recommended dosages.
- ✓ After superchlorinating/brominating, wait until the disinfectant level is down to 3-5 parts per million [ppm] before using the spa.
- ✓ Keep chemicals out of reach of children and pets.
- ✓ Keep containers closed when not in use.
- ✓ Do not use contents of unlabeled containers.
- ✓ Never add water to chemicals. If called for by the instructions, add chemicals to water.
- ✓ Dispose of empty containers as instructed on the label.
- ✓ Never handle chemicals with your bare hands.
- ✓ Store chemicals in a cool, dry, clean place [not under spa].

The following table lists the total water system capacity for all Emerald Spas and will help you to determine the dosage of chemicals.

Spa Series	Max. Capacity [gal.]	Useable [gal.]
199	210	170
499	290	200
509	390	340
595	400	300
599/C2009	465	370
699/C3009	440	330
799/C5009	450	340
899/C7009	640	500
1009SE	235	180
1409SE	350	280

- pH Control

pH
Level

8.2

above 7.6

7.8

Add
Acid

7.6

7.2

} Ideal

6.8

Below 6.8
Add
Soda Ash**Caution:**

Do not use your spa until the pH level of the water is between 7.2 and 7.6. A pH level below 7.2 or above 7.6 may damage the spa shell and power pack, and void your warranty.

All water is either acidic, alkaline, or neutral. pH is defined as a method of measuring this characteristic. A pH level of 7.0 would be neutral. A pH level above 7.0 would be alkaline while a pH level below 7.0 would be acidic. The pH level of your spa water must be kept between 7.2 and 7.6. Above 7.6 the water will become discolored and cloudy. pH levels below 7.2 will cause corrosion to metals in the circulation system. Both high and low pH levels will cause eye irritation. Improper pH levels also reduce the effectiveness of disinfectants.

Maintain an ideal pH level as follows:

1. Test the pH level of the water regularly with a reliable test kit.
2. Adjust the pH level as required.
 - Increase pH by adding soda ash.
 - Decrease pH by adding sodium bisulfate.
3. Refer to the table below and determine the dosage level per 100 gallons.
4. Add chemicals to at least one gallon of water.
5. Pour the mixture into the spa with circulation system on.
6. Wait at least 3 hours. Recheck the pH level.

High pH - Add Sodium Bisulfate (pH down)

Test Reading	Dosage [per 100 gal.]
Above 8.4	.24 oz. [1 teaspoon]
8.0 to 8.4	.16 oz. [.7 teaspoon]
7.8 to 8.0	.08 oz. [.4 teaspoon]
7.2 to 7.6	Ideal

Low pH- Add Soda Ash (pH up)

Test Reading	Dosage [per 100 gal.]
Less than 6.5	.6 oz. [3.6 teaspoons]
6.5 to 6.8	.45 oz. [3 teaspoons]
6.8 to 7.2	.12 oz. [.7 teaspoons]
7.2 to 7.6	Ideal

Note:

If the instructions that accompany the pH adjusting chemicals differ from those given here, follow the instructions that come with the chemicals.

• Disinfecting Your Spa

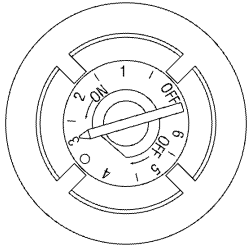

Dispenser Adjustment

The higher the setting, the more disinfectant will be dispensed.

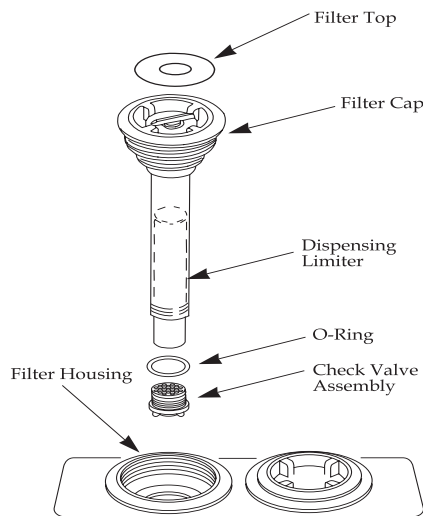

Recharging Your Dispenser



Warning:

Risk of fire and/or explosion. Under no circumstance should you mix trichloro-s-triazinetrione with bromine or other chemicals. Use one chemical only. Never mix. Never switch from one chemical to the other without thoroughly cleaning out the previously used chemicals.

Disinfectants [chlorine or bromine] have strong oxidizing properties that kill bacteria and destroy other materials.

Your spa is equipped with a disinfectant dispenser, enabling you to keep your spa clean and healthful with a minimum of effort. This dispenser is designed to use bromine or trichloro-s-triazinetrione tablets of the slow dissolving type.

Adjust your disinfectant dispenser as follows:

1. Verify proper disinfectant level by checking the spa water with an appropriate test kit. A level between 3-5 ppm should be maintained.
2. Start by adjusting the control valve on the dispenser to position 3.
3. Make small gradual changes in the setting until your test kit verifies the proper setting. [The higher the setting, the more disinfectant will be dispensed].
4. Increase the disinfectant level to 5 - 10 ppm once a week. This is called "superchlorination" or "superbromination". This procedure aids in the formation of active disinfectant.

Recharge your disinfectant dispenser as follows:

1. Turn off power at GFCI or circuit breaker before performing any service or see standby mode section for DS-2 & DS-4 power pack.
2. Remove disinfectant dispenser from filter housing.
3. Remove check valve assembly by turning counterclockwise.
4. Fill with trichloro-s-triazinetrione or bromine tablets or sticks which are 1" in diameter.
5. Install check valve assembly. Do not overtighten.
6. Install dispenser on filter.
7. Turn on at GFCI or circuit breaker.

- **Ozone Generator**
[optional]

An Ozone generator will supplement disinfectants and provide the following benefits:

- kills bacteria and viruses
- destroys matter which might discolor water
- does not affect the pH level of the water
- safe for bathers and equipment
- has no "chemical" smell
- automatic and requires little or no maintenance
- reduces the need for disinfectants

Refer to your ozone generator owner's manual for information on service and maintenance.

- **Other Water Chemistry Considerations**

Note:

When water evaporates, minerals from the water and the chemicals are left behind. As the level of these minerals increases, water treatment becomes more and more difficult. Therefore, at some point (between 4-12 weeks, depending on use), it is easier and less costly to drain and refill the spa instead of continuing to treat the same water.

Total Alkalinity-

Total Alkalinity is important because it helps to keep the pH in the proper range. Test with an appropriate test kit, and adjust as needed following the instructions supplied with the test kit. If you are using trichloro-s-triazinetrione as a disinfectant, adjust to 60-100 ppm. If you are using bromine as a disinfectant, adjust to 100-150 ppm. Higher levels may cause cloudy water and scale formations, while lower levels may lead to corrosion and uncontrollable pH variations.

Calcium Hardness-

Proper calcium hardness levels will help you to maintain other water quality values such as pH and total alkalinity, and help to avoid cloudy water and/or scaling on the tub surfaces, equipment, and piping. Maintain the calcium hardness of your spa at 200 ppm when using trichloro-s-triazinetrione as a disinfectant. For bromine, maintain the calcium hardness between 150-300 ppm. Test with an appropriate test kit and adjust as needed, following the instructions supplied with the test kit.

Total Dissolved Solids-

Tap water contains 50-300 ppm total dissolved solids [TDS]. When the level goes above 1500 ppm in a spa, the efficiency of sanitizers is reduced and corrosion is accelerated. To reduce TDS levels, replace some or all of the spa water.

MAINTAINING YOUR SPA

- Draining the Water
- Cleaning the Spa Shell
- Cleaning the Filter
- Space Saver II Filtration System
- Relamping the Underwater Light
- Standby Mode
- Winterizing Your Spa
- The Spa Cabinet



● Draining the Water

Note:

Chemically treated water may damage plants. Place the garden hose in a safe discharge area.

Note:

Some water will be left in the bottom of the spa and in your plumbing lines. This small amount of water can be mixed with fresh water without consequence. If 100% draining is required, a small submersible pump or a wet/dry shop vac should be used. If winterizing your spa please turn to page 47 for complete instructions.

Caution:

Do not allow the pump to run without water. Running the pump without water will cause pump damage and void the warranty.

To drain your Emerald spa:

1. Turn off the power at GFCI or circuit breaker before draining your spa.
2. Open the equipment access panel and attach a garden hose to the drain valve.
3. Open the drain valve and allow water to drain from your spa. Be sure all circulating valves are open.

To drain your Cygnus or SE spa without taking access panel off:

1. Turn off the power at GFCI or circuit breaker before draining your spa.
2. Remove black drain cap and pull out hose with fitting to allow for gravity drain.
3. Attach a garden hose to the drain fitting and open the ball valve. (note: this method does require longer drain time)

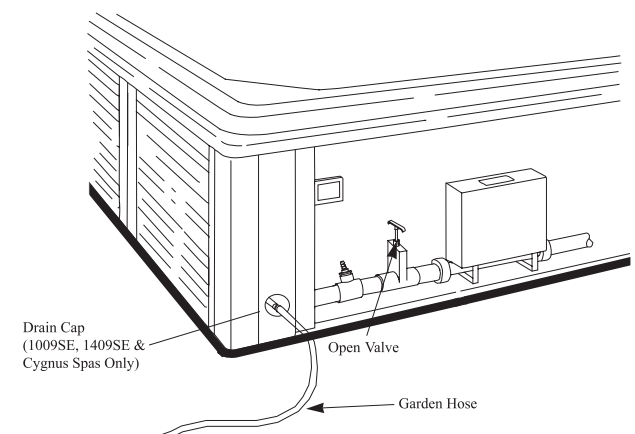

● Cleaning the Spa Shell

Note:

Do not use scouring cleansers or solvents; damage to the acrylic finish will result.

Note:

Do not use strong solvents such as gasoline, acetone, or denatured alcohol; damage to the acrylic finish will result.

● Cleaning the Filter

Use a nonabrasive household cleaner to clean all spa shell surfaces and fixtures. Do not use scouring cleansers or solvents; damage to the acrylic finish will result.

Your Emerald Whirlpool Spa is manufactured using LUCITE XL 1000 continuous-cast cross-linked acrylic sheet. This material provides a strong chemical-resistant high gloss surface that is hard, nonporous, and impermeable to water.

Given proper care, the polished, lustrous surface of LUCITE XL 1000 sheet will retain its appearance for many years. To clean your spa be sure to use a soft absorbent cloth with any of the commercially available nonabrasive foam or liquid agents in general cleaning concentrations. Always rinse thoroughly with clean water and a soft chamois or moist cellulose sponge.

Cleaning agents containing strong abrasives such as scouring powders or strong solvents such as gasoline, acetone, or denatured alcohol should not be used to clean the acrylic surface of your spa.

Fine scratches may be minimized by the use of a mild automobile cleaner-polish. The cleaner-polish has a fine abrasive action, and its wax content tends to fill small scratches to make them less visible.

1. Turn off power at GFCI, circuit breaker before performing any service. For DS-2 and DS-4 models you may want to use the stand-by mode by pressing the ▲ or ▼ pad, then the "light" pad for the DS-2 and if you have a DS-4 you simply press "time" then the ▼ pad.
2. Using a filter key, open filters and remove elements.
3. Clean the filter elements as required:
 - Spray with a garden hose to remove trapped dirt.
 - Soak in a solution of water and automatic dishwasher detergent to remove body oils and other contaminants or see your dealer for recommended cleaning supplies.
 - Inspect the elements for damage and replace as required.
 - Rinse thoroughly.
4. Place clean filter elements in housing and install filter tops.
5. Turn the power on at GFCI, circuit breaker. For Stand-by mode, touch any keypad to resume spa operation for DS-2 and DS-4.

• SpaceSaver II Filtration System Diagram

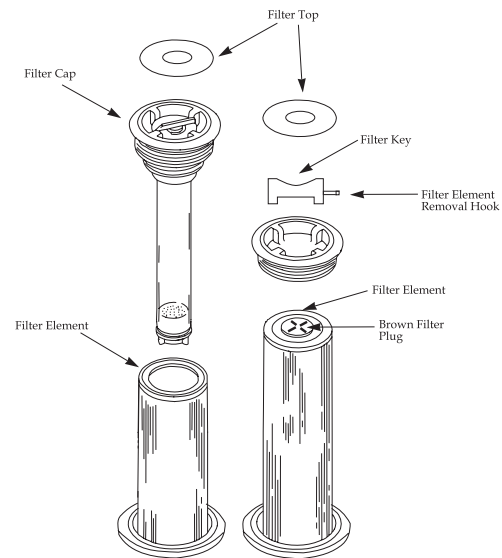

• Relamping the Underwater Light



Caution:

Do not attempt to remove or reinstall the light lens without using the proper tool provided.

The underwater light should be relamped from the under side of the spa as follows:

1. Disconnect the power from the spa.
2. Locate the light fixture on the back of the spa inside the cabinet.
3. Remove the old bulb and install a new bulb.

During those times when the spa will not be used for extended periods. (ex. vacations)

1. Adjust the temperature setting to 60° F.
2. Turn air intake controls off.
3. Cover the spa to reduce heat loss and evaporation, and to prevent unauthorized use.

Note:

Turning air intake controls off prevents air from entering the water and helps reduce heat loss.

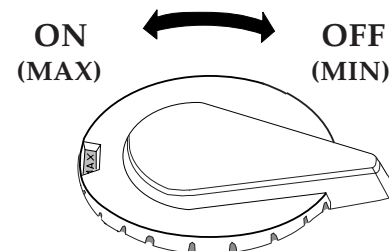

● Winterizing Your Spa



Caution:

Do not use Automobile type radiator antifreeze.

Note:

It is possible to use the air blower (if equipped) to purge the air lines. Ask your dealer for assistance if you want to use this procedure.

Note:

If you cannot drain all the water, especially from the blower air injector lines, add an inhibited propylene glycol type antifreeze to any remaining water. Propylene Alcohol can be purchased most commonly in a store with a Recreational Vehicle section.

● The Spa Cabinet

Note:

Do not apply varnish, shellac, or surface sealants to the wood. They tend to react with chemicals in the wood and the UV rays of the sun to cause yellowing, peeling, and flaking.

The following procedure should be followed if you choose to deactivate your spa for the winter months.

1. Drain all water from spa using drain hose.
2. Unplug the pump power cords from the control outputs.
3. Press the blower keypad and run blower until all air lines are dry.
4. Vacuum out each jet and air injector with a shop vac.
5. Remove any remaining water in the spa with a sponge or cloth.
6. Turn power off at main power supply panel.
7. Disconnect all plumbing from power pack at unions. Open T-valves to allow water to drain.
8. Open drain valve.
9. Connected to the manifold is a hose that allows drainage of the manifold. Connect a hose to the spigot and drain the manifold.
10. Clean spa as instructed in maintenance section.
11. Use a locking spa cover to keep water out and prevent unauthorized use.

The red cedar cabinet of your spa is protected with a wood sealer. It is normal for the cabinet to take on a weathered appearance with time and exposure to the elements.

Protect and revive the wood surface with a light sanding and the application of a wood preservative or tongue oil. Since Emerald uses only decay-resistant woods in its spa construction, you may choose to allow your cabinet to age with time and weather.

Durabilt Cabinet

If you have purchased an optional Durabilt cabinet, know that the outer surface of the Durabilt Cabinet is made completely of a synthetic material. To clean, take a dampened rag with mild dish soap and wash the outside panels.

- Spas equipped with Lite Leader, SS-1D & SS-3D Power Systems



WARNING:

Risk of electrical shock. Electrical troubleshooting should be done by qualified technicians.

WARNING:

Risk of electrical shock. Disconnect power cord from receptacle or turn power off at main service panel before removing fuse.

TROUBLESHOOTING

Problems	Things to Check
<p>Power system inoperative (No LED display on the panel).</p> <p>Fault indicated by spa control display message.</p>	<ol style="list-style-type: none"> 1. Not plugged in (120v). 2. Circuit breaker tripped or not turned on. 3. Ground fault circuit interrupter tripped. 4. Fuse in control box blown. <p>1. OH: Overheat Protection (spa is de activated). If a malfunction occurs and spa water reaches 112° F., the system will completely shut down. In such a condition, DO NOT ENTER THE WATER. Turn off all power to the spa and contact your dealer or service organization. Overheating may also occur if you set the low speed pump to operate for extended periods of time. In this instance, remove the spa cover and allow the water to cool to below 110° F. Touch the MODE (#) pad to reset the system. If the water is still hotter than the set temperature, touch the blower pad to cool the spa.</p> <p>FLO: (Constant display) A pressure switch has malfunctioned. Contact your dealer or service organization.</p> <p>FLO: (Flashing display):</p> <ul style="list-style-type: none"> - A suction valve may be closed. Check position of valve. - The amount of water may be inadequate. Be sure the spa is properly filled. - A pressure switch has malfunctioned. The spa will operate, but the heater will not activate. Contact your dealer or service organization. <p>SN: Open sensor (spa is deacti vated). The high-limit sensor or water temperature sensor is not working. Call your dealer or service organization.</p>

- Spas equipped with Lite Leader, SS-1D, SS-3D Power Systems [continued]

Problems	Things to Check
Pump does not prime.	<ol style="list-style-type: none"> 1. Circulation T-valve closed. 2. Not enough water in the spa. 3. Air locked. Bleed air as described previously in this manual. (pg. 36)
Hydrotherapy jets do not operate.	<ol style="list-style-type: none"> 1. Filter clogged. 2. Pump not primed. 3. Air intake valve(s) closed. 4. Jet venturi nozzles plugged or missing.
Spa does not heat.	<ol style="list-style-type: none"> 1. Thermostat set too low. 2. Low flow, pump not primed, or water level too low. 3. Pressure switch not sensing enough pressure. 4. Heater element defective.
Spa heats, but not to set temperature.	<ol style="list-style-type: none"> 1. Spa not covered or covered properly sealing the spa cover to the top edge of the spa. Heat loss is greater for an uncovered spa. High wind, low humidity also increase heat loss.

- Spas equipped with DS-2 & DS-4 Power Systems

**WARNING:**

Risk of electrical shock. Electrical troubleshooting should be done by qualified technicians.

WARNING:

Risk of electrical shock. Disconnect power cord from receptacle or turn power off at main service panel before removing fuse.

TROUBLESHOOTING (cont.)

Problems	Things to Check
<p>Power system inoperative (No LCD display on the panel).</p> <p>Fault indicated by spa control display message.</p>	<p>1. Circuit breaker tripped or not turned on. 2. Fuse in control box blown.</p> <p>1. OH: Overheat Protection (spa is de activated). If a malfunction occurs and spa water reaches 112° F., the system will completely shut down. In such a condition, DO NOT ENTER THE WATER. Turn off all power to the spa and contact your dealer or service organization. Overheating may also occur if you set the low speed pump to operate for extended periods of time. In this instance, remove the spa cover and allow the water to cool to below 110° F. Touch the MODE (#) pad to reset the system. If the water is still hotter than the set temperature, touch the blower pad to cool the spa.</p> <p>FLO: (Constant display) A pressure switch has malfunctioned. Contact your dealer or service organization. FLO: (Flashing display):</p> <ul style="list-style-type: none"> - A suction valve may be closed. Check position of valve. - The amount of water may be inadequate. Be sure the spa is properly filled. - A pressure switch has malfunctioned. The spa will operate, but the heater will not activate. Contact your dealer or service organization. <p>ICE: Freeze protection. If a freeze condition is detected, all pumps will automatically activate. This is a normal spa function; corrective action may not be necessary. Freeze protection is enabled regardless of the spa's status.</p>

- **Spas equipped with DS-2 & DS-4 Power Systems**
[continued]

Problems	Things to Check
<p>Fault Indicators (continued).</p>	<p>ILOC: The spa is disabled in a standby mode. This mode is typically used to clean the spa filter. To reset press any button.</p> <p>COOL: Temperature set back. If spa water is more than 20° F cooler than the temperature set point, the heater will automatically activate to provide freeze protection. This is a normal function; no corrective action is necessary.</p> <p>SN1: Open sensor (spa is deactivated). The high-limit temperature sensor is not working. This must be repaired by a dealer or service organization.</p> <p>SN3: Open sensor (spa is deactivated). The water sensor is not working. This also must be repaired by a dealer or service organization.</p> <p>Pd: (Only an indicator to DS-4 systems). Battery backup. Power has been cut off to the spa, and it is using its battery backup to preserve its settings (for short interruptions). The control panel will be disabled until power returns to the unit.</p> <p>Econ: (Only an indicator to DS-2 systems). Designates that the spa is in economy mode. The message is flashed alternately with the current spa temperature and COOL until the spa water is 15° F cooler than the set temperature.</p>

- Spas equipped with
DS-2 & DS-4
Power Systems
[continued]

Problems	Things to Check
Pump does not prime.	<ol style="list-style-type: none"> 1. Circulation T-valve closed. 2. Not enough water in the spa. 3. Air locked. Bleed air as described previously in this manual. (pg. 36)
Hydrotherapy jets do not operate.	<ol style="list-style-type: none"> 1. Filter clogged. 2. Pump not primed. 3. Air intake valve(s) closed. 4. Jet venturi nozzles plugged or missing.
Spa does not heat.	<ol style="list-style-type: none"> 1. Thermostat set too low. 2. Low flow, pump not primed, or water level too low. 3. Pressure switch not sensing enough pressure. 4. Heater element defective.
Spa heats, but not to set temperature.	<ol style="list-style-type: none"> 1. Spa not covered or covered properly sealing the spa cover to the top edge of the spa. Heat loss is greater for an uncovered spa. High wind, low humidity also increase heat loss.

Electrical Schematics

Lite Leader

W	H	Neutral
B	L	Hot
R	E	Hot
GRN		Ground

USE COPPER
WIRE MIN. 8 AWG 16A/32A 60Hz

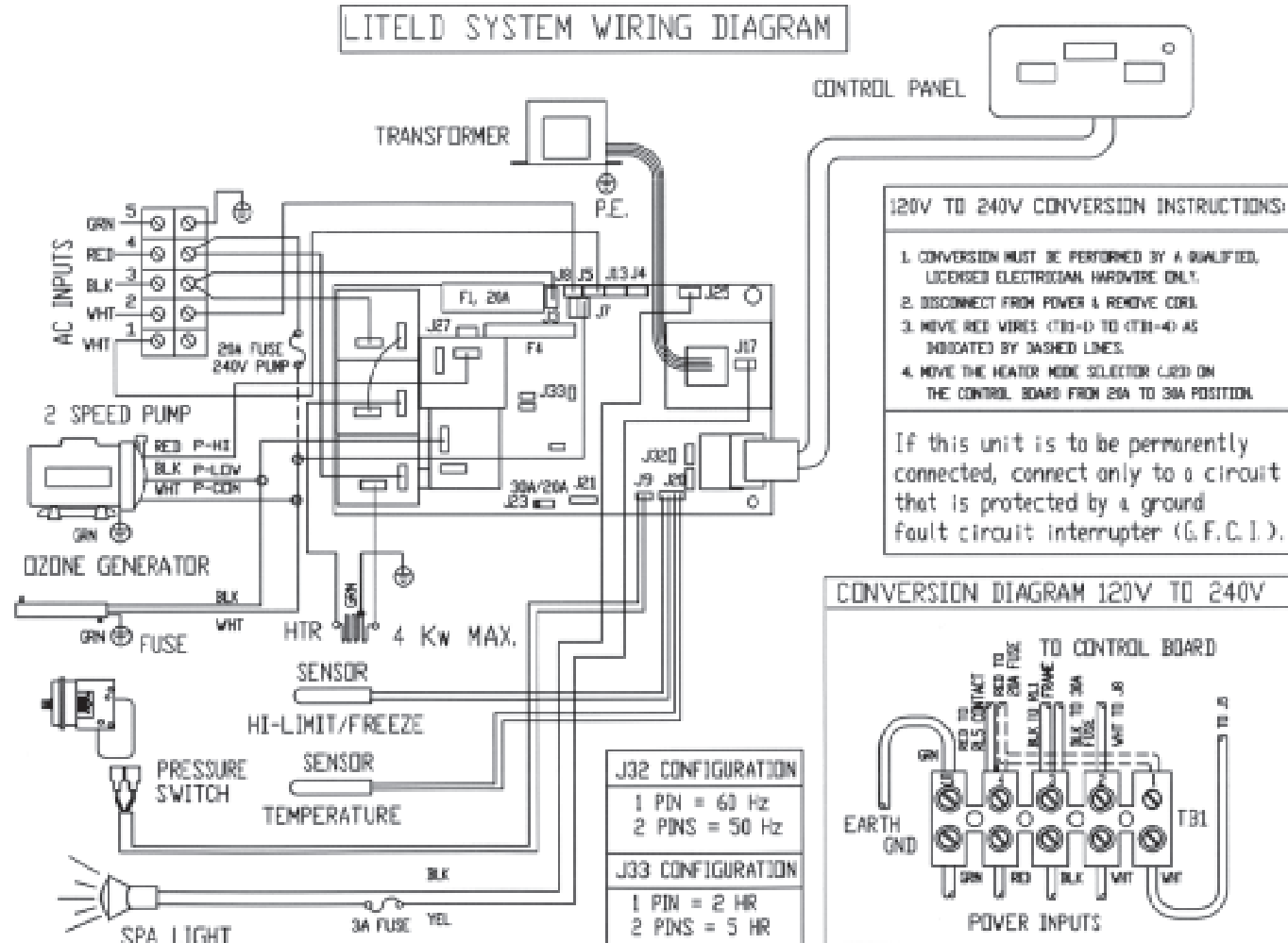

SS-1D System Wiring Diagram

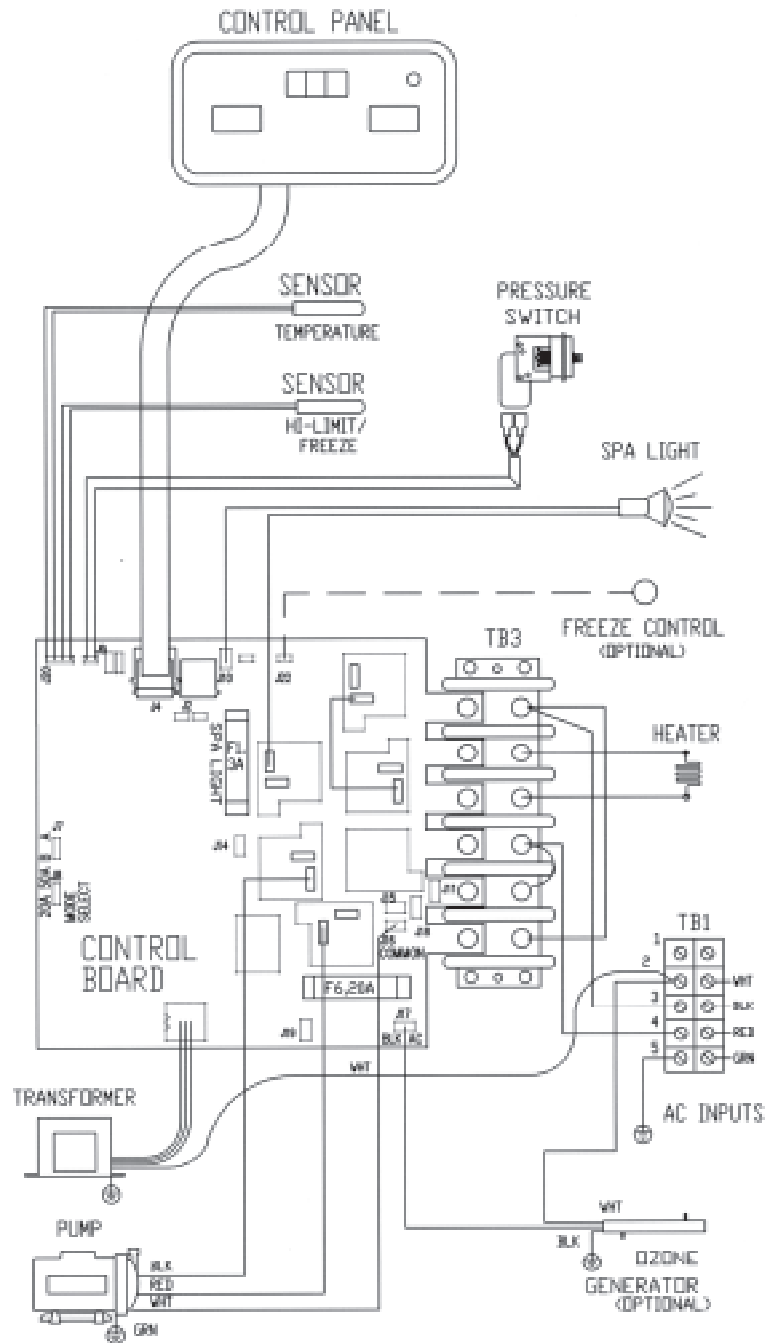

SS-3D System Wiring Diagram

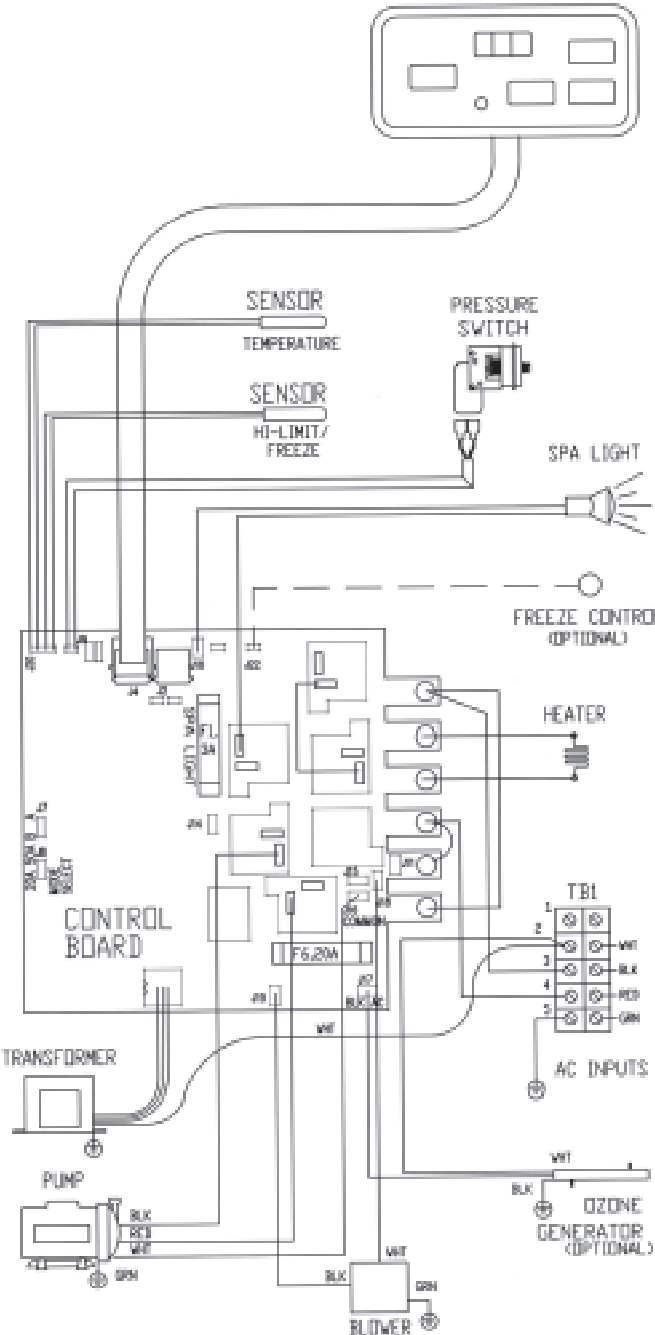

DS-2 System Wiring Diagram

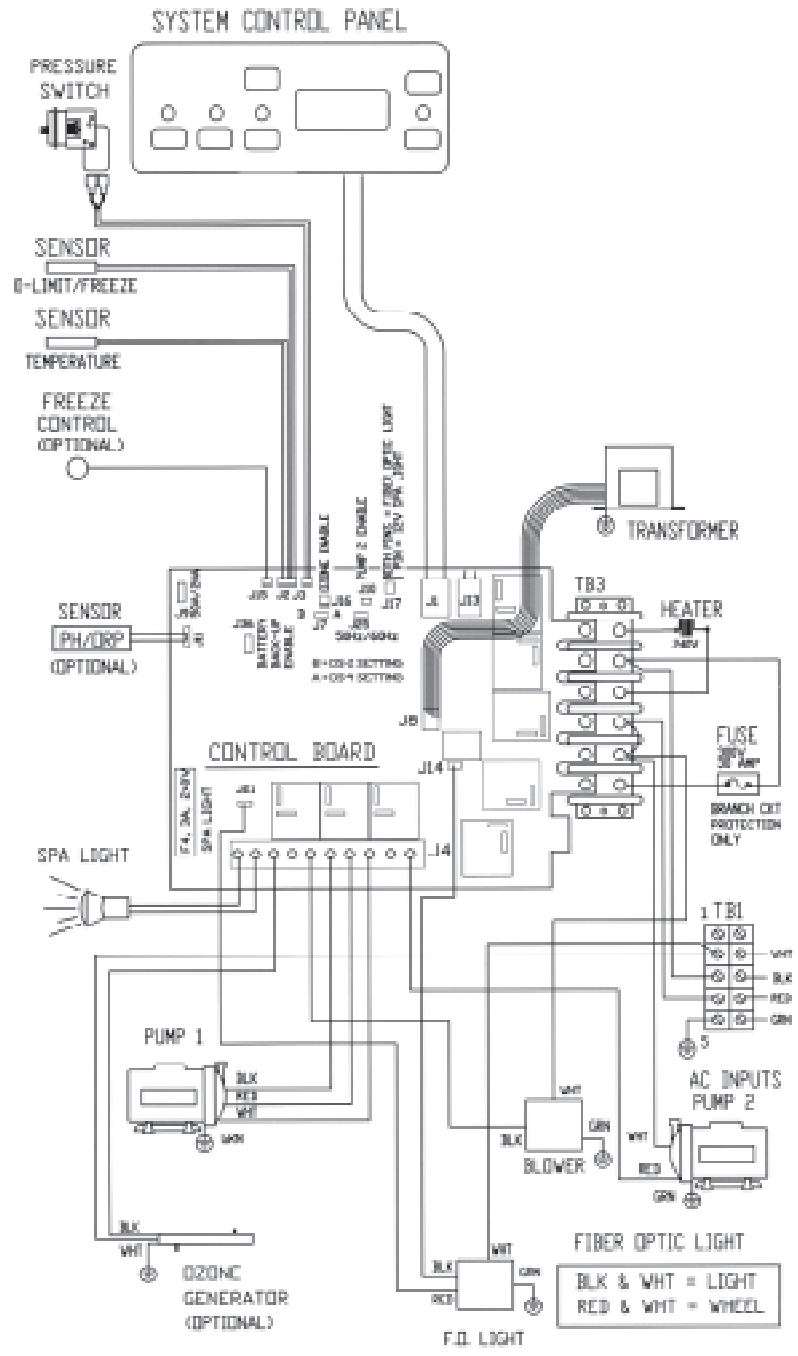

DS-4 System Wiring Diagram

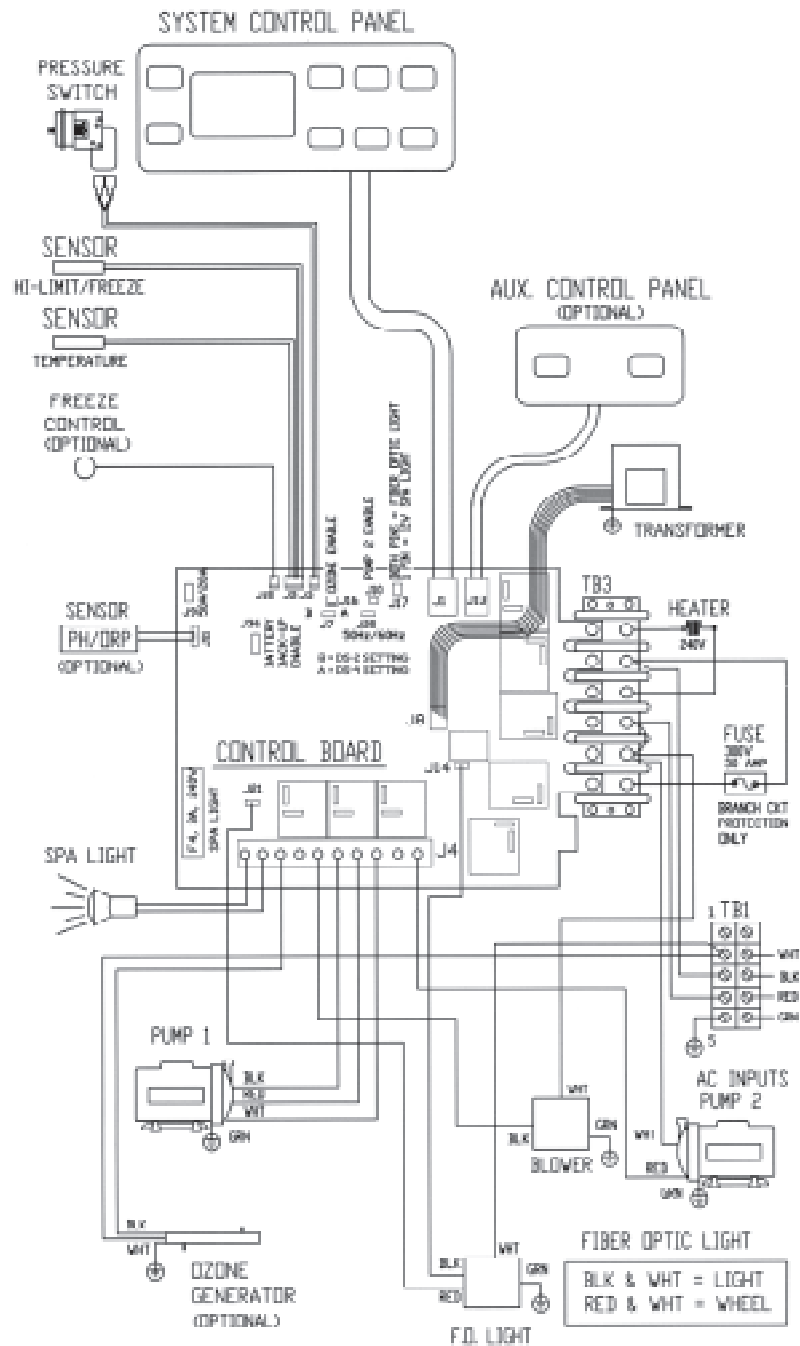



4150 East Paris Ave.
Kentwood, MI 49512
Ph 616.698.2601
Fx 616.698.0861
800.766.7727
www.emeraldspa.com
e-mail:info@emeraldspa.com

